

# Fusion<sup>®</sup> PC Conversion Kit

3A7318C

EN

**For converting the Fusion AP spray gun to a Fusion PC spray gun for use with ProConnect™ fluid cartridges. For professional use only.**

3500 psi (24.5 MPa, 245 bar) Maximum Working Pressure

80-130 psi (0.56-0.9 MPa, 5.6-9.0 bar) Air Inlet Pressure Range

200°F (94°C) Maximum Fluid Temperature

See page 2 for model information.



## Important Safety Instructions

Read all warnings and instructions in this manual and in your Fusion PC and Fusion AP gun manual before using the equipment. Save all instructions.

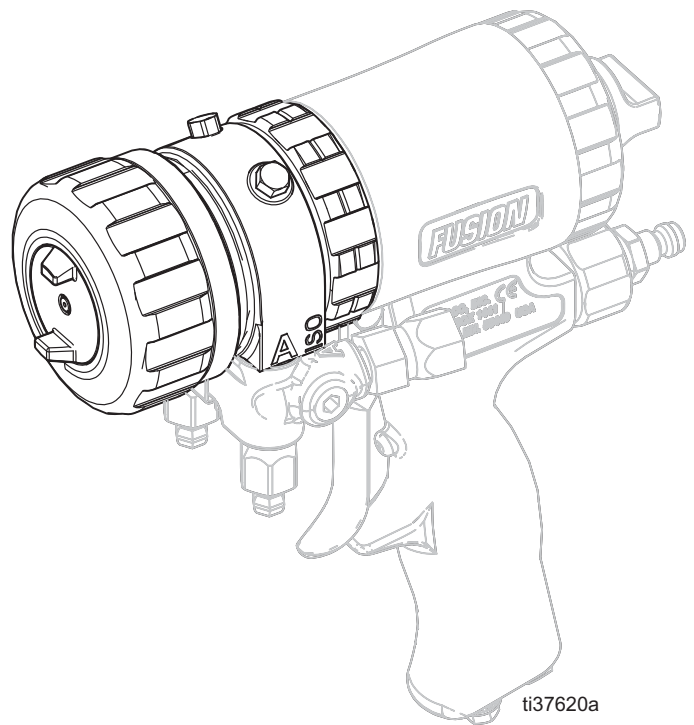

ti37620a

## Related Manuals

Manual in English	Description
309550	Fusion AP Spray Gun Instruction Manual
3A7314	Fusion PC Spray Gun Instruction Manual

# Overview

The side-sealing components from the Fusion Air Purge (AP) gun have been integrated into a single fluid cartridge, the ProConnect (PC) fluid cartridge. To use ProConnect fluid cartridges with your Fusion AP gun, install the Fusion PC conversion kit.

Once the conversion kit is installed, refer to your Fusion PC spray gun manual for full Warnings, Installation, Operation, Maintenance, Repair, Troubleshooting, and Technical Specifications information. See **Related Manuals**, page 1.

## Models

### Round Pattern Conversion Kits

Conversion Kit	Mix Chamber			
	Part Number	Impingement Port Size in. (mm)	Equivalent Size	Pattern at 24 in. (61 cm) from target in. (mm)
25P700	PC29RD	0.029 (0.70)	00	8 (203)
25R087	PC37RD	0.037 (0.94)	00-01	9 (227)
25P701	PC42RD	0.042 (1)	01	11 (279)
25P703	PC47RD	0.0469 (1.18)	01-02	11 (279)
25P702	PC52RD	0.052 (1.3)	02	12 (305)
25R088	PC60RD	0.060 (1.50)	03	14 (356)

### Flat Pattern Conversion Kit

Conversion Kit	Mix Chamber			Flat Tip		
	Part Number	Impingement Port Size in. (mm)	Equivalent Size	Part Number	Pattern Size in. (mm)	Orifice Size in. (mm)
25R089	PC29FL	0.029 (0.70)	00	FT0438	8-10 (203-254)	0.038 (0.97)

### Bare Conversion Kit

**NOTE:** Bare conversion kits include the same accessories as standard conversion kits, without a mix chamber and drill bits. A round air cap is provided.

Conversion Kit
25P704

# Component Identification

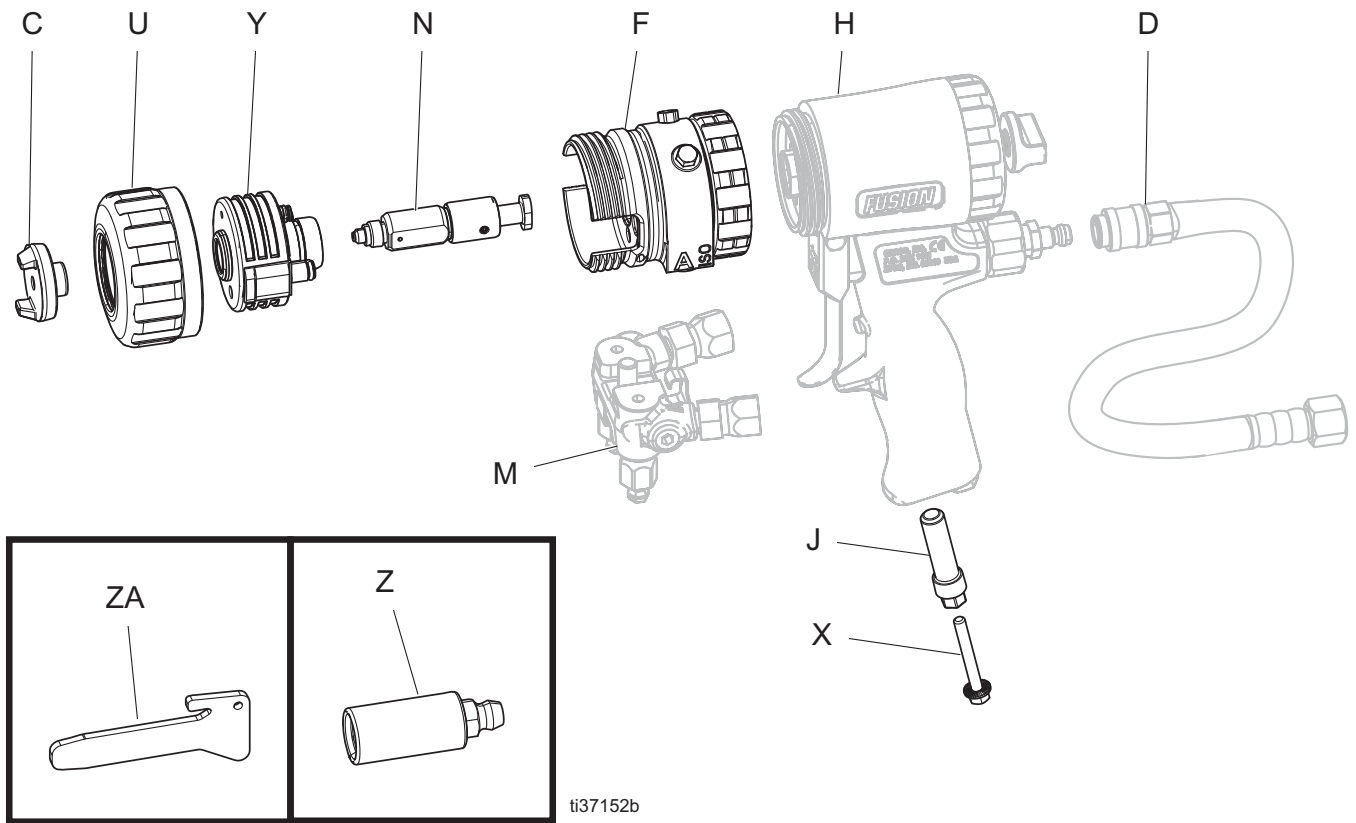

ti37152b



**Key**

- C Air Cap
- D Air Line Quick Coupler (not included)
- F Fluid Housing
- H Handle (not included)
- J Jack Screw Holder/Optional Air Inlet
- N Mix Chamber



**Key**

- M Gun Fluid Manifold (not included)
- U Front Retaining Ring
- X Jack Screw
- Y PC Fluid Cartridge
- Z Grease Tool
- ZA Divider Tool

# Installation

<b>! WARNING</b>				
				
<p><b>TOXIC FUMES HAZARD</b>                  Spraying or dispensing fluids that contain isocyanates creates potentially harmful mists, vapors, and atomized particles. Skin contact may cause inflammation or sensitization. To avoid serious injury or death, wear personal protective equipment at all times and see your Fusion PC gun manual for <b>Important Isocyanate (ISO) Information</b>.</p> <p><b>PERSONAL PROTECTIVE EQUIPMENT</b>                  Always wear appropriate personal protective equipment and cover all skin when spraying, servicing equipment, or when in the work area. Protective equipment helps prevent serious injury, including long-term exposure; inhalation of toxic fumes, mists or vapors; allergic reaction; burns; eye injury and hearing loss.</p>				

## Install the Conversion Kit

<b>! WARNING</b>				
				
<p><b>PRESSURIZED FLUID HAZARD</b>                  This equipment stays pressurized until pressure is manually relieved. To help prevent serious injury from pressurized fluid, such as skin injection, and splashing fluid, follow the <b>Pressure Relief Procedure</b> in your Fusion PC manual when you stop spraying and before cleaning, checking, or servicing the equipment.</p>				

1. Follow the **Pressure Relief Procedure** in your Fusion PC gun manual and your proportioner manual.
2. Disconnect quick coupler (D) on the air hose from the gun.

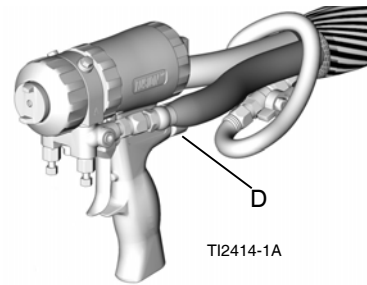

3. Remove the fluid manifold (M) from the gun and clean the sealing surface.

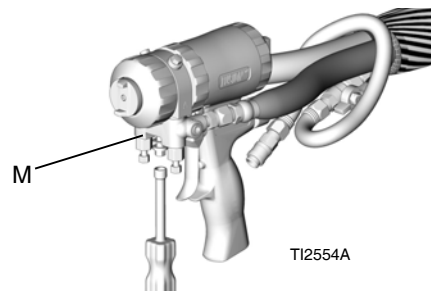

4. Follow the **Remove Front End** procedure from your Fusion PC gun manual.
5. Refer to your Fusion AP spray gun manual for instructions to clean and store Fusion AP front end components.
6. Install Fusion PC fluid housing (F).
  - a. Check that o-ring (OR) is in position. Liberally lubricate o-rings, gun handle (H), threads of the lock ring, and outside of the lock ring. Orient the fluid housing (F) as required for desired fluid manifold mounting.
  - b. Screw lock ring onto handle (H) as far as possible by hand.

- c. Rotate the fluid housing (F) to engage slots and tabs. Push on front end to ensure it is properly seated. Continue screwing lock ring onto handle (H) very securely. When properly assembled, lock ring is snug against handle.

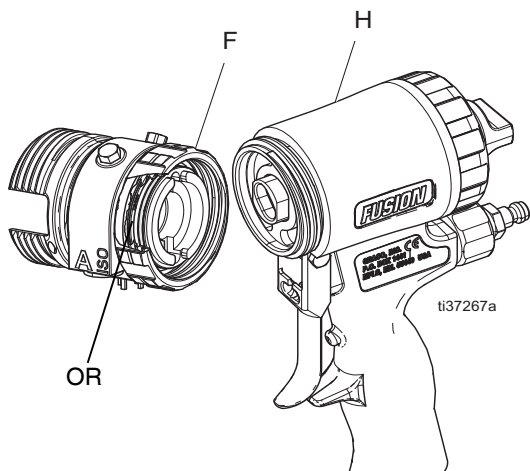

- 7. Replace the plug in the gun handle (H) with the jack screw holder (J). Torque to 125-135 in-lb (14-15 N•m). Store the jack screw (X) in the holder (J) while not in use.

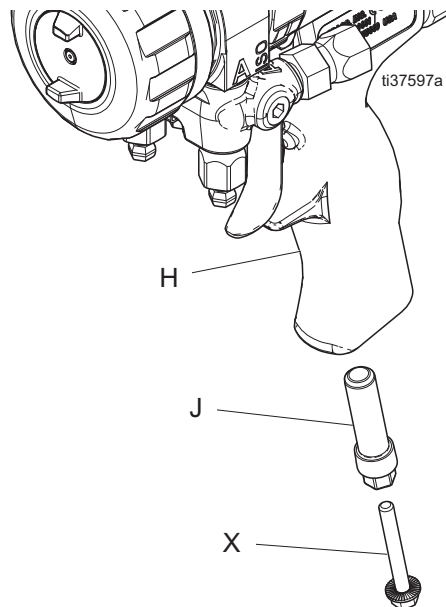

- 8. Proceed to the **Installation** procedure in your Fusion PC spray gun manual.

# Parts

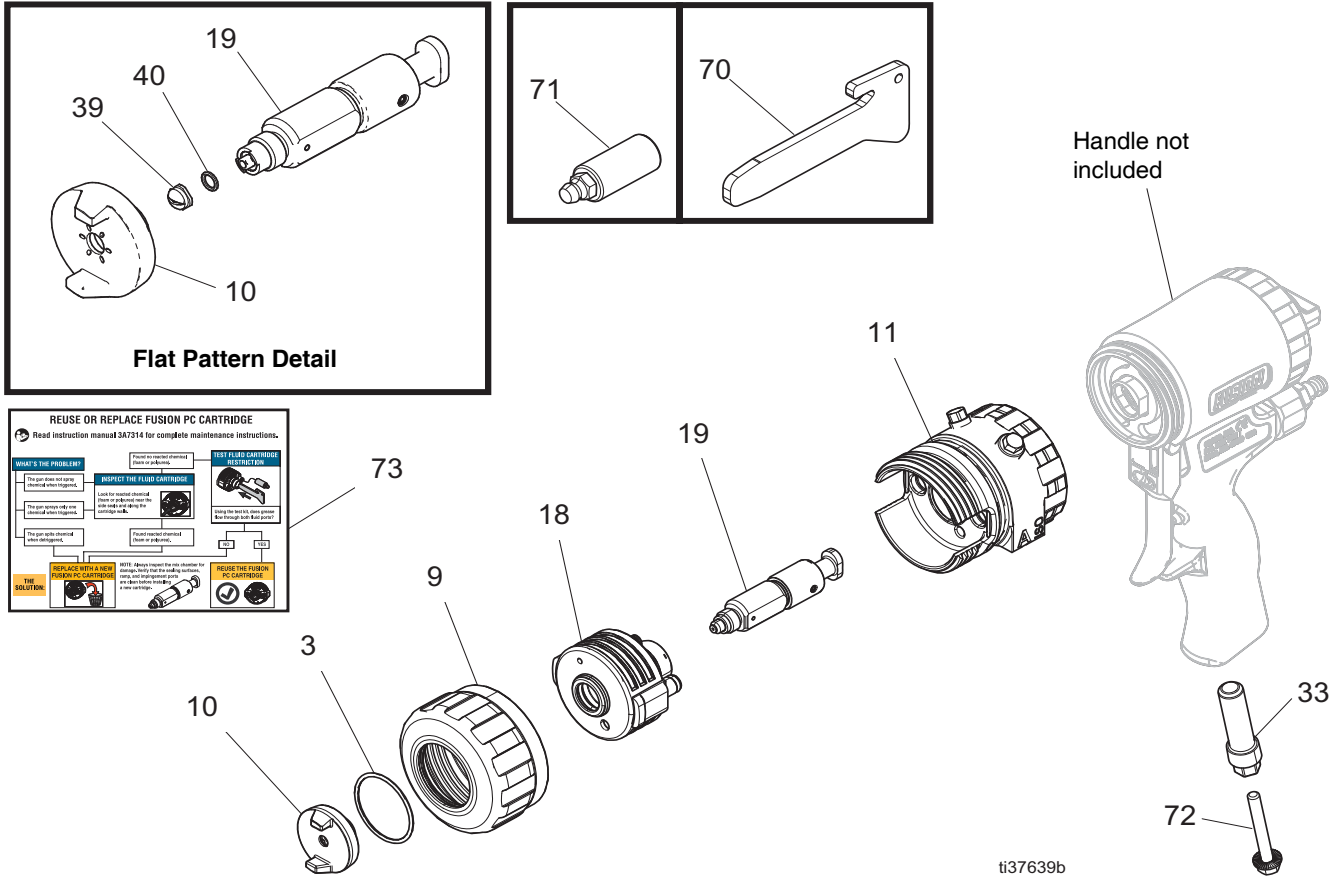

**NOTE:** See your Fusion PC spray gun manual for all orderable part numbers.

Ref.	Description	Qty.	Ref.	Description	Qty.
3	O-RING, PTFE	1	40	O-RING, PTFE, flat tip models only	1
9	RING, retaining, front, Fusion PC	1	55▲	TAG, warning; not shown	1
10	AIR CAP	1	58	GREASE, tube, 4 oz; not shown. SDS available at <a href="http://www.graco.com">www.graco.com</a>	1
11	HOUSING, fluid, Fusion PC	1	70	TOOL, divider	1
18	CARTRIDGE, Fusion PC	3	71	TOOL, grease	1
19	CHAMBER, mix (not included with Bare Conversion Kit)	1	72	SCREW, jack	1
33	PLUG, Fusion PC tool holder, 1/4 NPT	1	73	LABEL, troubleshooting guide	1
36▲	CARD, warning; not shown	1			
39	TIP, flat, flat tip models only	1			

▲ Replacement safety labels, tags, and cards are available at no cost.



# Graco Information

For the latest information about Graco products, visit [www.graco.com](http://www.graco.com).

For patent information, see [www.graco.com/patents](http://www.graco.com/patents).

**TO PLACE AN ORDER**, contact your Graco distributor or call to identify the nearest distributor.

**Phone:** 612-623-6921 **or Toll Free:** 1-800-328-0211, **Fax:** 612-378-3505

*All written and visual data contained in this document reflects the latest product information available at the time of publication.  
Graco reserves the right to make changes at any time without notice.*

Original instructions. This manual contains English. MM 3A7318

**Graco Headquarters:** Minneapolis

**International Offices:** Belgium, China, Japan, Korea

**GRACO INC. AND SUBSIDIARIES • P.O. BOX 1441 • MINNEAPOLIS MN 55440-1441 • USA**  
**Copyright 2020, Graco Inc. All Graco manufacturing locations are registered to ISO 9001.**

[www.graco.com](http://www.graco.com)  
Revision C, January 2020