

Instructions—Parts List



321 MM (12.625 IN.)

Premier™ Air Motor

308213V

EN

100 psi (0.7 MPa, 7 bar) Maximum Air Input Pressure

Part No. 222800, Series C

Standard Motor

United States Patent Nos. 5,189,943; Des. 345,138; 2,032,617; 5,363,739

Taiwan Patent No. 050264

Canada Patent No. D75390

Korea Patent No. 152224

Other US and Foreign Patents Pending



Important Safety Instructions

Read all warnings and instructions in this manual.
Save these instructions.

See page 2 for Table of Contents.

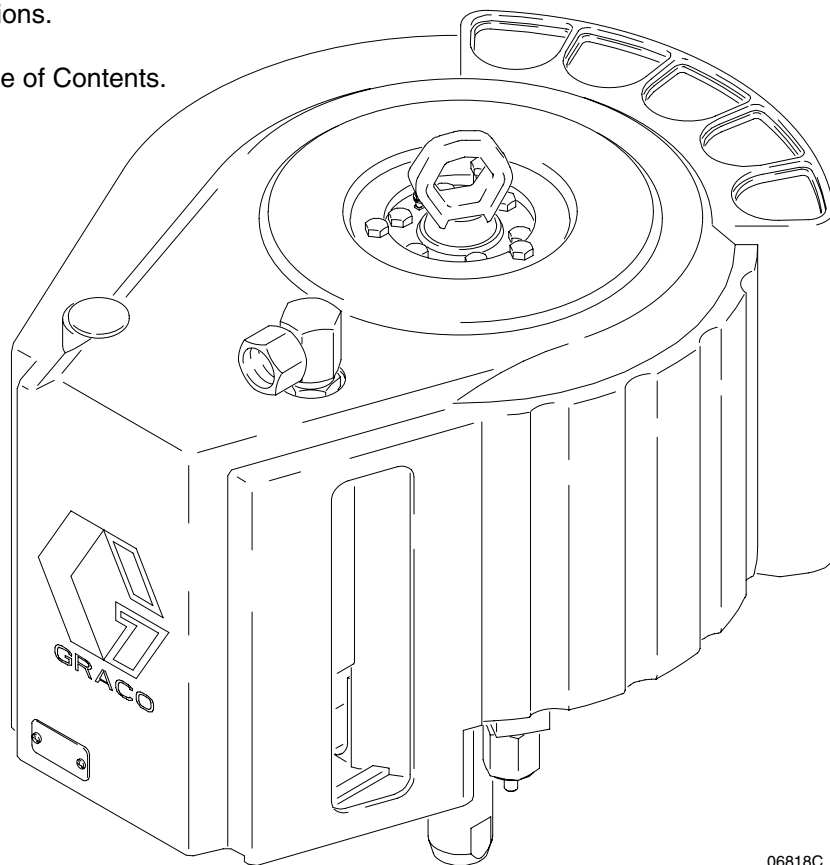

06818C



PROVEN QUALITY. LEADING TECHNOLOGY.

Table of Contents

Warnings	3	Air Valve Service	13
Installation/Operation	6	Subplate and Rocker Assemblies	17
Troubleshooting the Air Motor	8	Piston and Piston Rod Seals	19
Preventive Maintenance Schedule	8	Parts Drawings and Parts Lists	21
Checking for Leaks or Damaged Parts	8	Air Motor	21
Check Chart	8	Air Valve 222799	24
Service	10	Technical Data	26
Pressure Relief Procedure	10	Dimensions	27
Required Service Tools	10	Graco Standard Warranty	28
Air Motor Shroud	11	Graco Information	28
Air Valve Replacement	11		

Symbols

Warning Symbol



This symbol alerts you to the possibility of serious injury or death if you do not follow the instructions.

Caution Symbol



This symbol alerts you to the possibility of damage to or destruction of equipment if you do not follow the instructions.

WARNING



INSTRUCTIONS

EQUIPMENT MISUSE HAZARD

Equipment misuse can cause the equipment to rupture or malfunction and result in serious injury.

- This equipment is for professional use only.
- Read all instruction manuals, tags, and labels before operating the equipment.
- Use the equipment only for its intended purpose. If you are uncertain about usage, call your Graco distributor.
- Do not alter or modify this equipment. Use only genuine Graco parts and accessories.
- Check equipment daily. Repair or replace worn or damaged parts immediately.
- Do not exceed the maximum working pressure of the lowest rated system component. Refer to the **Technical Data** on page 26 for the maximum working pressure of this equipment.
- Use fluids and solvents which are compatible with the equipment wetted parts. Refer to the **Technical Data** section of all equipment manuals. Read the fluid and solvent manufacturer's warnings.
- Do not kink or overbend hoses or use hoses to pull equipment.
- Route hoses away from traffic areas, sharp edges, moving parts, and hot surfaces. Do not expose Graco hoses to temperatures above 180°F (82°C) or below -40°F (-40°C).
- Wear hearing protection when operating this equipment.
- Do not lift pressurized equipment.
- Do not lift the equipment by the Premier air motor lift ring if the total weight of the equipment exceeds 550 lb (250 kg).
- Comply with all applicable local, state, and national fire, electrical, and safety regulations.

WARNING



SKIN INJECTION HAZARD

Spray from the gun, hose leaks, or ruptured components can inject fluid into your body and cause extremely serious injury, including the need for amputation. Fluid splashed in the eyes or on the skin can also cause serious injury.



- Fluid injected into the skin might look like just a cut, but it is a serious injury. **Get immediate surgical treatment.**
- Do not point the gun at anyone or at any part of the body.
- Do not put your hand or fingers over the spray tip.
- Do not stop or deflect leaks with your hand, body, glove or rag.
- Do not “blow back” fluid; this is not an air spray system.
- Always have the tip guard and the trigger guard on the gun when spraying.
- Check the gun diffuser operation weekly. Refer to the gun manual.
- Be sure the gun trigger safety operates before spraying.
- Lock the gun trigger safety when you stop spraying.
- Follow the **Pressure Relief Procedure** on page 10 whenever you: are instructed to relieve pressure; stop spraying; clean, check, or service the equipment; and install or clean the spray tip.
- Tighten all fluid connections before operating the equipment.
- Check the hoses, tubes, and couplings daily. Replace worn, damaged, or loose parts immediately. Permanently coupled hoses cannot be repaired; replace the entire hose.
- Use only Graco approved hoses. Do not remove the spring guard that is used to help protect the hose from rupture caused by kinks or bends near the couplings.



MOVING PARTS HAZARD

Moving parts, such as the air motor piston, can pinch or amputate your fingers.

- Keep clear of all moving parts when starting or operating the pump.
- Before servicing the equipment, follow the **Pressure Relief Procedure** on page 10 to prevent the equipment from starting unexpectedly.

WARNING



FIRE AND EXPLOSION HAZARD

Improper grounding, poor ventilation, open flames or sparks can cause a hazardous condition and result in a fire or explosion and serious injury.

- Ground the equipment and the object being sprayed. Refer to **Grounding** on page 7.
- If there is any static sparking or you feel an electric shock while using this equipment, **stop spraying immediately**. Do not use the equipment until you identify and correct the problem.
- Provide fresh air ventilation to avoid the buildup of flammable fumes from solvents or the fluid being sprayed.
- Keep the spray area free of debris, including solvent, rags, and gasoline.
- Electrically disconnect all equipment in the spray area.
- Extinguish all open flames or pilot lights in the spray area.
- Do not smoke in the spray area.
- Do not turn on or off any light switch in the spray area while operating or if fumes are present.
- Do not operate a gasoline engine in the spray area.
- Keep a fire extinguisher in the work area.



TOXIC FLUID HAZARD

Hazardous fluid or toxic fumes can cause serious injury or death if splashed in the eyes or on the skin, inhaled, or swallowed.

- Know the specific hazards of the fluid you are using.
- Store hazardous fluid in an approved container. Dispose of hazardous fluid according to all local, state and national guidelines.
- Always wear protective eyewear, gloves, clothing and respirator as recommended by the fluid and solvent manufacturer.

Installation/Operation

CAUTION

The Premier air motor is designed for intermittent duty cycle applications, such as spraying of corrosion control materials, or adhesive and sealant applications. It is not recommended for continuous duty circulating systems. Contact your Graco distributor for further application information.

NOTE: Reference numbers and letters in parentheses in the text refer to the callouts in the figures and the parts drawings.

NOTE: Always use Genuine Graco Parts and Accessories, available from your Graco distributor. If you supply your own accessories, be sure they are adequately sized and pressure rated for your system.

System Accessories

WARNING

A bleed-type master air valve and a fluid drain valve are required in your system. These accessories help reduce the risk of serious injury, including fluid injection and splashing of fluid in the eyes or on the skin, and injury from moving parts if you are adjusting or repairing the pump.

The bleed-type master air valve relieves air trapped between this valve and the pump after the air is shut off. Trapped air can cause the pump to cycle unexpectedly. Locate the valve close to the pump.

The fluid drain valve assists in relieving fluid pressure in the displacement pump, hose, and gun. Triggering the gun to relieve pressure may not be sufficient.

Mounting Accessories

Mount the motor to suit the type of installation planned. Motor dimensions and the mounting hole layout are shown on page 27.

If you are mounting the motor on an elevator or a cart, refer to the separate manuals supplied with those components for installation and operation instructions.

Air Line Accessories

The following air line accessories are available from Graco. Contact your Graco distributor for help in designing a system to suit your particular needs.

- **A bleed-type master air valve** is required in your system to relieve air trapped between it and the air motor when the valve is closed (see the **WARNING** at left). Be sure the bleed valve is easily accessible from the motor, and is located **downstream** from the air regulator. Order Part No. 113163.
- **An air regulator** controls pump speed and outlet pressure by adjusting the air pressure to the motor. Locate the regulator close to the motor, but **upstream** from the bleed-type master air valve.
- **An air line filter** removes harmful dirt and moisture from the compressed air supply.
- **An air line lubricator** adds oil to the compressed air supply at an adjustable rate, to automatically lubricate the air motor.
- **A pump runaway valve** senses when the pump is running too fast and automatically shuts off the air to the motor. A pump which runs too fast can be seriously damaged. Install closest to the motor air inlet.

Installation/Operation

Grounding

⚠ WARNING



FIRE AND EXPLOSION HAZARD
Before operating the pump, ground the system as explained below. Also read the section **FIRE AND EXPLOSION HAZARD** on page 5.

1. *Pump*: use a ground wire and clamp (supplied). See Fig. 1. Loosen the grounding lug locknut (W) and washer (X). Insert one end of a 1.5 mm² (12 ga) minimum ground wire (Y) into the slot in lug (Z) and tighten the locknut securely. Connect the other end of the wire to a true earth ground. Order Part No. 237569 Ground Wire and Clamp.

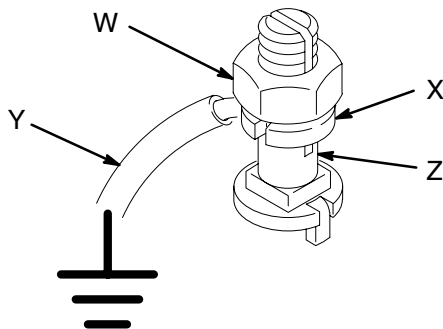

Fig. 1

0864

2. *Air and fluid hoses*: use only electrically conductive hoses.
3. *Air compressor*: follow manufacturer's recommendations.
4. *Spray gun*: ground through connection to a properly grounded fluid hose and pump.
5. *Fluid supply container*: follow your local code.
6. *Object being sprayed*: follow your local code.
7. *Solvent pails used when flushing*: follow your local code. Use only metal pails, which are conductive, placed on a grounded surface. Do not place the pail on a nonconductive surface, such as paper or cardboard, which interrupts the grounding continuity.
8. *To maintain grounding continuity when flushing or relieving pressure*, hold a metal part of the spray gun firmly to the side of a grounded *metal* pail, then trigger the gun.

Troubleshooting the Air Motor

Preventive Maintenance Schedule

The operating conditions of your particular system determine how often maintenance is required. Establish a preventive maintenance schedule by recording when and what kind of maintenance is needed, and then determine a regular schedule for checking your system.

Air Motor Cylinder

Premier motors require lubrication and continuous maintenance including the replacement of the air motor cylinder casting at least every 15,000,000 cycles of use. Use Premier cylinder repair kit 16P239.

Repair or replace the Air Valve assembly (222799) whenever motor stalling or hesitation occurs. This ensures the motor does not overtravel and cause added stress to the cylinder casting.

WARNING



EXPLOSION HAZARD

Without proper maintenance, the cylinder casting (120026) may fracture unexpectedly due to metal fatigue. This is a potentially hazardous condition and may result in serious injury. The precise life of this casting is difficult to predict and is affected by the operating pressure, number of cycles, lubrication and air valve maintenance.

Checking the Air Motor for Leaks or Damaged Parts

If the pump is not performing well, the problem could be in the air motor. To check the air motor, perform the following steps.

1. Close the bleed-type master air valve. Disconnect the air line.
2. Remove the shroud. Refer to page 11.

3. Reinstall the air inlet fitting (22). Reconnect the air line.
4. Open the bleed-type master air valve and set the air regulator to about 0.1 MPa, 1 bar (14 psi). Observe the rocker arms and trip rods for smooth operation. Check at points A through E in Fig. 2 by listening or feeling for escaping air, or squirting a small amount of oil around the suspected leak. The oil will bubble if air is leaking. Refer to the sections noted in the Check Chart for detailed service procedures.

Check Chart

NOTE: Service the air valve every 3 million cycles. If the air motor stalls, service the air valve immediately.

Ref. Letter	Problem	Refer to:
A	Rocker assemblies (29) not operating.	Service rocker arms (see pages 17 and 18).
B	Air escaping around trip rod or push rods.	Service trip rod and air valve (see pages 11–16). Service push rod seals (see pages 17 and 18).
C	Air escaping around air valve (25).	Service air valve and air valve gaskets (see pages 11–16).
D	Air escaping around or out of exhaust manifold (45).	Service slide blocks and air valve seals (see pages 11–16).
E	Air escaping around piston rod (4).	Service piston and rod seals (see pages 19 and 20).
F	Air motor stalls.	Service air valve (see the NOTE above, and refer to pages 11–16). Install the detent, trip rod, and air valve kits (see pages 21–24).

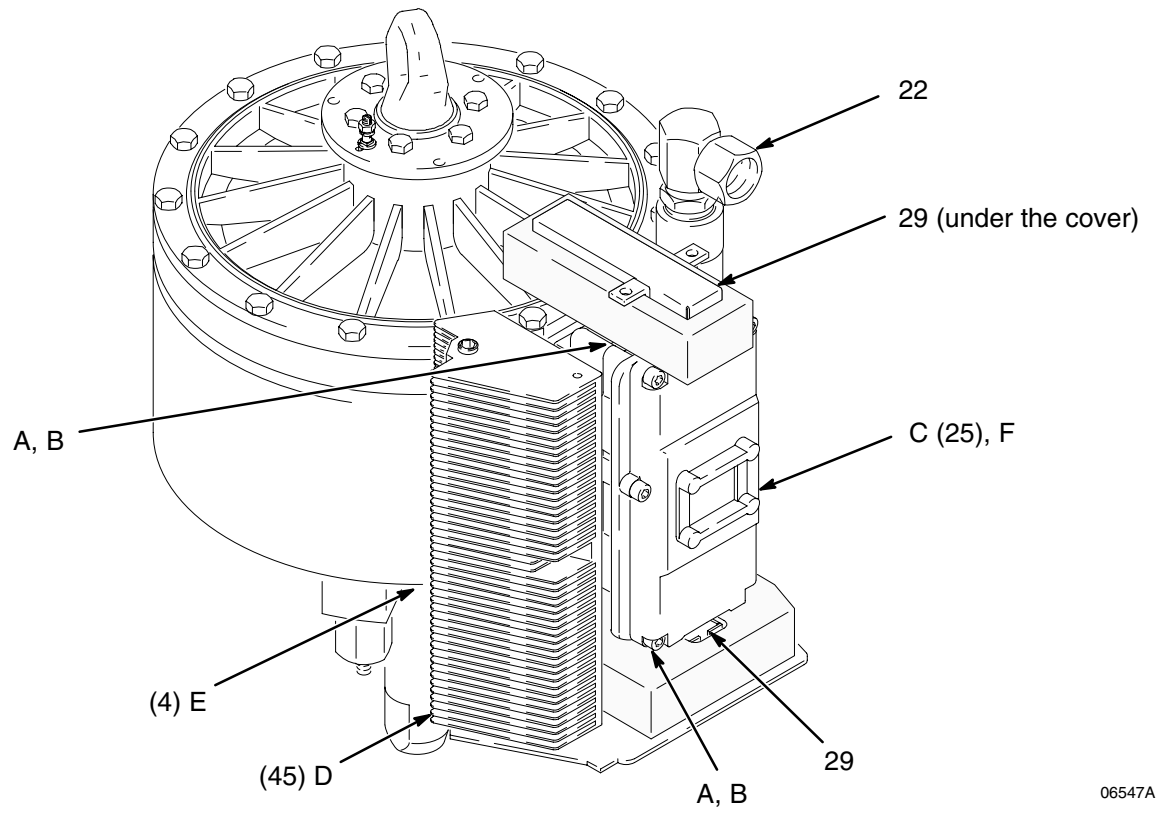

Fig. 2

06547A

Service

Pressure Relief Procedure

WARNING



SKIN INJECTION HAZARD

The system pressure must be manually relieved to prevent the system from starting or spraying accidentally. Fluid under high pressure can be injected through the skin and cause serious injury. To reduce the risk of an injury from injection, splashing fluid, or moving parts, follow the **Pressure Relief Procedure** whenever you:

- are instructed to relieve the pressure,
- stop spraying/dispersing,
- check or service any of the system equipment,
- or install or clean the spray tips/nozzles.

1. Lock the gun/valve trigger safety.
2. Shut off the air supply to the pump.
3. Close the bleed-type master air valve (required in your system).
4. Unlock the gun/valve trigger safety.
5. Hold a metal part of the gun/valve firmly to the side of a grounded metal pail, and trigger the gun/valve to relieve pressure.
6. Lock the gun/valve trigger safety.
7. Open the drain valve (required in your system) and/or pump bleeder valve, having a container ready to catch the drainage.
8. Leave the drain valve open until you are ready to spray/dispense again.

If you suspect that the spray tip/nozzle or hose is completely clogged, or that pressure has not been fully relieved after following the steps above, very slowly loosen the tip guard retaining nut or hose end coupling and relieve pressure gradually, then loosen completely. Now clear the tip/nozzle or hose.

Required Service Tools

- Phillips screwdriver
- Flat blade screwdriver
- 16 mm box wrench
- Set of metric socket wrenches
- Set of metric allen wrenches
- Set of adjustable wrenches
- Torque wrench
- Pliers
- Rubber mallet
- O-ring pick
- Soft brush (for cleaning)
- Large vise, with soft jaws
- Thread sealant
- Thread lubricant
- Multi-purpose grease
- Heavy-duty lithium grease (for air valve)

Service

WARNING



To avoid serious injury and equipment damage, do not lift the equipment by the Premier air motor lift ring if the total weight of the equipment exceeds 550 lb (250 kg). The lift ring cannot support that weight.

Air Motor Shroud

NOTE: Reference numbers and letters in parentheses in the text refer to the callouts in the figures and the parts drawing.

Disassembly

WARNING

To reduce the risk of serious injury whenever you are instructed to relieve pressure, always follow the **Pressure Relief Procedure** on page 10.

1. Stop the pump at the middle of its stroke. Relieve the pressure before performing any service.
2. Disconnect the air supply and the ground wire.
3. If necessary, disconnect the displacement pump from the air motor, as explained in your separate pump manual.
4. Unscrew the air inlet swivel (22). See Fig. 3.
5. Remove the three screws (13) and washers (51). Lift the shroud (53) off the motor.

Reassembly

1. Make sure the rocker arm cover pad (63) and cover plug (57) are in place.
2. Place the shroud (53) on the motor so the three notches in the top center align with the outer holes in the lift ring (3). Apply sealant to the three screws (13) and attach the shroud to the lift ring with the screws and washers (51).
3. Install the air inlet swivel (22).
4. If the displacement pump was removed, reconnect it as explained in your separate pump manual.
5. Reconnect the air supply and the ground wire.

Air Valve Replacement

NOTE: Service the air valve every 3 million cycles. If the air motor stalls, service the air valve immediately.

To **replace** the entire air valve assembly, order Part No. 222799 and perform the following procedure. To **service** the air valve, refer to pages 13–16.

NOTE: Air Valve Repair Kit 222959 includes the subplate seals (27†) and gasket (26†).

WARNING

To reduce the risk of serious injury whenever you are instructed to relieve pressure, always follow the **Pressure Relief Procedure** on page 10.

1. Stop the pump at the middle of its stroke. Relieve the pressure before performing any service.
2. Remove the air motor shroud as described under **Air Motor Shroud Disassembly**, at left.
3. Use a 6 mm allen wrench to remove the six socket screws (28) holding the air valve (25) to the motor. Remove the air valve.
4. Inspect the subplate gasket (26†) and seals (27†) for wear or damage. Always replace the gasket (26†) when replacing the air valve. Grease the grooves of the slide plates (G), then install the seals (27†) in the grooves with the curved sides facing out (see the Detail in Fig. 3).
5. Grease the ends of the trip rod (106).
6. Install the new air valve (25), using a 6 mm allen wrench and the six socket screws (28). Torque to 22–23 N•m (195–205 in-lb).
7. Reinstall the air motor shroud as described under **Air Motor Shroud Reassembly**, at left.

Service

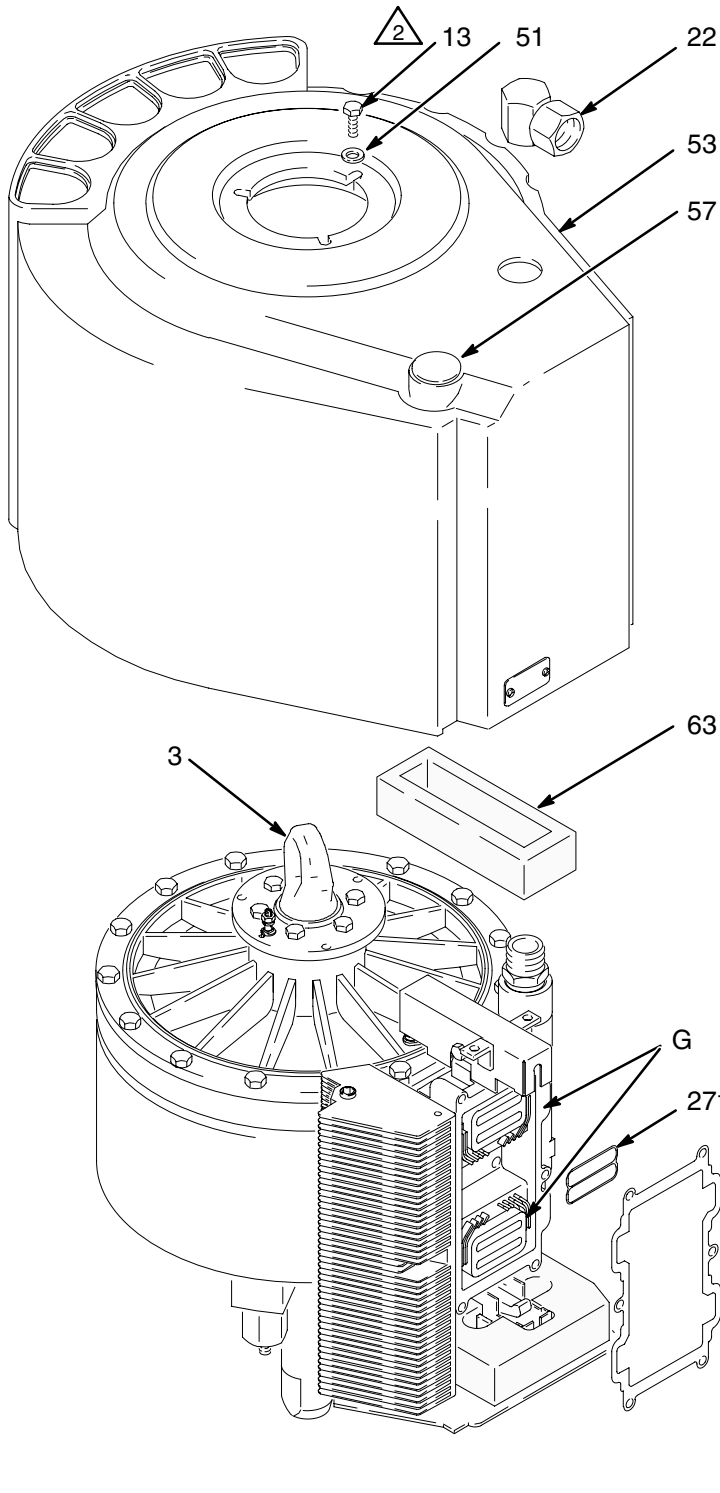

△1 Torque to 22–23 N•m (195–205 in-lb)

△2 Apply sealant.

△3 Grease ends of trip rod.

† These parts are included in Air Valve Repair Kit 222959, which may be purchased separately.

Detail of Slide Plate Seals

△4 Grease the grooves of the slide plates (G).

△5 Install the seals (27†) in the grooves of the slide plates (G) with the curved sides facing out.

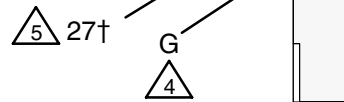

02301

Fig. 3

06549A

Service

Air Valve Service

NOTE: Service the air valve every 3 million cycles. If the air motor stalls, service the air valve immediately.

NOTE: Air Valve Repair Kit 222959 is available. Parts included in the kit are marked with a symbol (†). For the best results, use all the parts in the kit.

NOTE: Trip Rod Kit 222981 and Detent Kit 222982 are available to replace these complete assemblies. Parts included in Kit 222981 are marked with a symbol (‡) and parts included in Kit 222982 are marked with a checkmark (✓).

Disassembly

⚠ WARNING

To reduce the risk of serious injury whenever you are instructed to relieve pressure, always follow the **Pressure Relief Procedure** on page 10.

1. Stop the pump at the middle of its stroke. Relieve the pressure before performing any service.
2. Remove the air motor shroud as described under **Air Motor Shroud Disassembly**, on page 11.
3. Follow steps 3 and 4 under **Air Valve Replacement** on page 11.
4. Using a 4 mm allen wrench, remove the socket screws (104) holding the two slide plates (124) to the valve housing (101). Lift the slide plates off the housing, being careful not to scratch the polished surfaces. Clean the slide plate surfaces and edges and inspect for damage. See Fig. 4.
5. Lift the valve carriage (111) out of the valve housing (101). The detent assemblies (J) will slide out of the carriage; be careful not to drop them. Set them aside.
6. Remove the screws (104) holding the top rod fitting (103) to the valve housing (101). Turn the fitting 90° and remove it. Using an o-ring pick, remove the seal (102). Repeat for the bottom rod fitting.
7. Remove the trip rod assembly (T) from the housing (101). Set it aside.

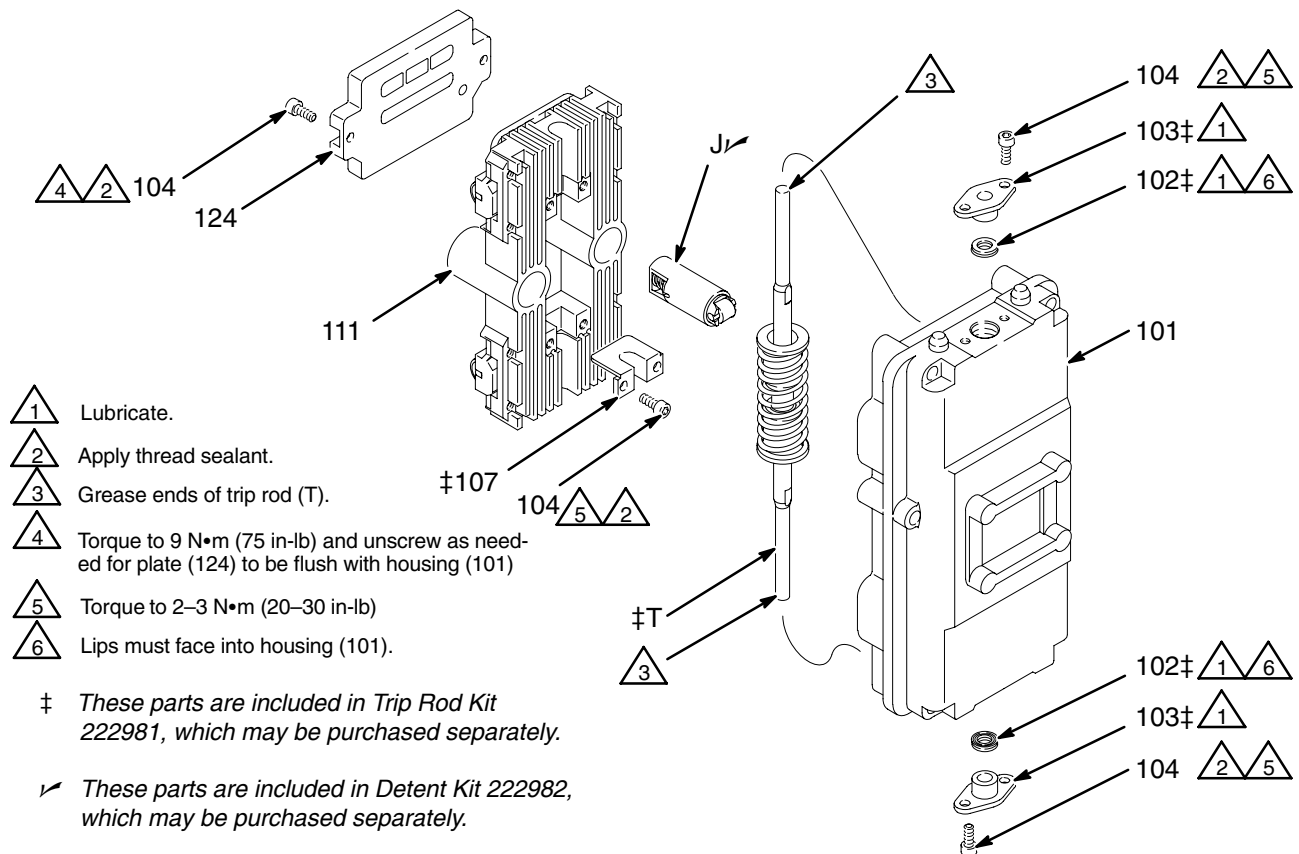

02271

Fig. 4

Service

8. With your fingers, snap the slide blocks (119) off of the valve carriage (111) to free the o-rings (120). Clean and inspect the slide blocks. See Fig. 8.
9. Remove the screws (104) and disassemble the bearing retainers (122), bearing rollers (121), and pins (123). Clean and inspect these parts.
10. Clean and inspect the valve carriage (111). Remove and replace the bearings (107†).
11. To disassemble the detents:

NOTE: If you are using Detent Kit 222982, it is not necessary to disassemble the detents. Just replace the old detents with the new ones provided in the kit (see **Reassembly**, step 9).

- a. Hold the detent roller (115) with a pliers while turning the plunger guide (113) slightly with a wrench, until the locking tabs of the guide disengage from the windows in the plunger (114). See Fig. 5.
- b. Use a flatblade screwdriver to pry out the detent roller (115) and pin (117). See Fig. 8.

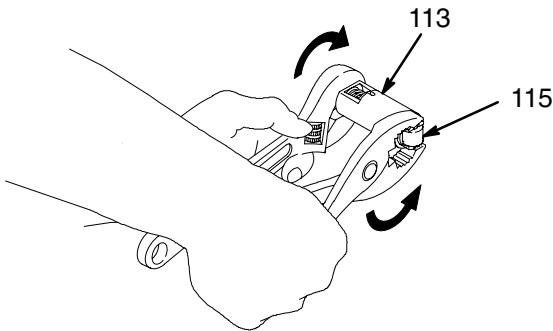

02249

Fig. 5

12. To disassemble the trip rod:

NOTE: If you are using Trip Rod Kit 222981, it is not necessary to disassemble the trip rod. Just replace the old trip rod with the new one provided in the kit (see **Reassembly**, step 3).

⚠ WARNING

MOVING PARTS HAZARD
Use caution when disassembling the trip rod. The trip rod spring (110) is under tension. When the trip rod is unscrewed tension is released, and parts may be projected through the air with considerable force.

- a. Place the flats of one trip rod (106) in a vise with soft jaws and unscrew the other trip rod (106) with a wrench. Be careful not to scratch the trip rods (106). See Fig. 8.
 - b. Disassemble the trip rod assembly. Inspect the press-fit bearings (129) in place in the spring guides (108). Clean and inspect all parts.
13. Inspect the two detent plates (105) in place on the valve housing (101). Remove if worn or damaged.
 14. Inspect the carriage bumpers (128) and replace if worn or damaged.

Reassembly

1. Install the detent plates (105) on the valve housing (101). Apply thread sealant and torque the screws (104) to 9 N.m (75 in-lb). Lubricate the plates with heavy-duty lithium grease. See Fig. 8.
2. Assemble the trip rod.

NOTE: If you are using Trip Rod Kit 222981, it is not necessary to assemble the trip rod. Skip steps a through c, and go to step 3.

- a. Press fit the bearings (129) flush with the inside surface of the spring guides (108). Apply thread sealant to one of the trip rods (106) and screw the shaft (109) onto the rod.
 - b. Install the spring guides (108) in the spring (110), with the flanges facing out. Apply thread sealant to the second trip rod and slide both trip rods into the spring guides.
 - c. Compress the spring so the shaft (109) and trip rod engage two or three threads. Place the flats of one trip rod in a vise with soft jaws. Use a wrench on the flats of the other rod and torque to 17–23 N•m (150–200 in-lb).
3. Install the trip rod assembly (T†) in the housing (101). Grease the ends of the trip rod. See Fig. 4.
 4. Lubricate the seal (102††) and slide it onto the trip rod (T†) and into the top hole of the housing (101) with the lips facing **into the housing**. Lubricate the rod fitting (103††) and install in the housing (see Fig. 4). Apply thread sealant and torque the screws (104) to 2–3 N•m (20–30 in-lb). Repeat for the bottom of the housing.

Service

5. Install the bearings (107†) on the valve carriage (111). Apply thread sealant and torque the screws (104) to 2–3 N•m (20–30 in-lb).
6. Install the bearing retainers (122) in the recesses of the valve carriage (111). Apply thread sealant and torque the screws (104) to 9 N•m (75 in-lb). Lubricate the pins (123✓) and install them in the bearing rollers (121✓). Lubricate the retainers (122) and install the bearing rollers (121✓).
7. Lubricate the o-rings (120†) and install them on the valve carriage (111). Snap the slide blocks (119) in place with the lip (K) facing toward the nearest end of the carriage. Be sure the o-rings do not roll out or twist. Lubricate the slide blocks.
8. Assemble the detents.

NOTE: If you are using Detent Kit 222982, it is not necessary to assemble the detents. Skip steps a and b, and go to step 9.

- a. Lubricate the roller pin (117) and install it in the detent roller (115). Lubricate the spring (112) and install in the plunger guide (113). Lubricate the plunger (114). Push the detent roller and pin assembly into the plunger.
- b. Align the windows in the plunger (114) with the tabs of the plunger guide (113). Stand the detent assembly on the workbench and push down on the plunger guide to seat the roller (115) in the plunger. Make sure the plunger tabs lock in the windows. See Fig. 6. Repeat for the other detent assembly.

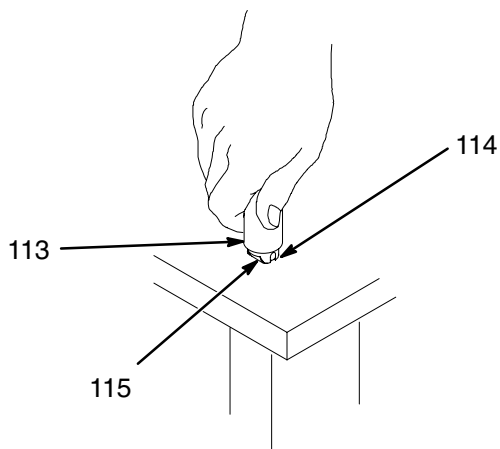
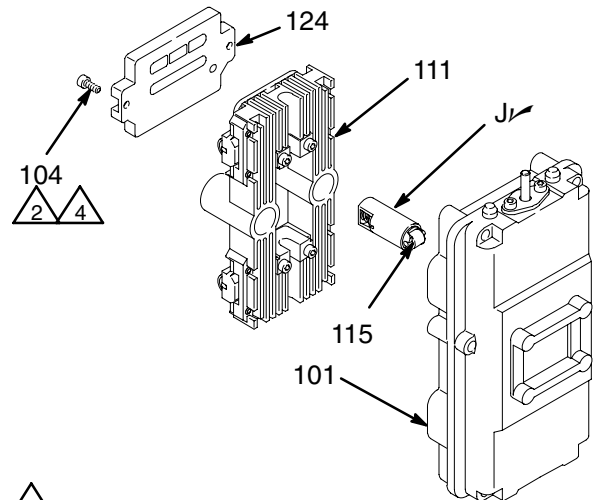



Fig. 6

02249

9. Insert the detent assemblies into the valve carriage (111) so the detent rollers (115) face out of the carriage. Set the carriage into the valve housing (101) so the detent rollers engage the detent plates (105) on the housing. See Fig. 7.



 Apply thread sealant.

 Torque to 9 N•m (75 in-lb) and unscrew as needed for plate (124) to be flush with housing (101).

✓ These parts are included in Detent Kit 222982, which may be purchased separately.

02269

Fig. 7

10. Grease the slide plates (124) and install them in the valve housing (101), with the o-ring grooves facing out of the housing. Apply thread sealant and torque the screws (104) evenly to 9 N•m (75 in-lb), then unscrew as needed for plates (124) to be flush with housing (101). See Fig. 7
11. Replace the subplate gasket (26†) and seals (27†). Grease the o-ring grooves of the slide plates (G), then install the seals (27†) in the grooves with the curved sides facing out (see the Detail in Fig. 3 on page 12).
12. Install the air valve (25), using a 6 mm allen wrench and the six socket screws (28). Torque to 22–23 N•m (195–205 in-lb). See Fig. 3.
13. Reinstall the air motor shroud as described under **Air Motor Shroud Reassembly**, on page 11.

Service

⚠ WARNING



MOVING PARTS HAZARD

Use caution when disassembling the trip rod. The trip rod spring (110) is under tension. When the trip rod is unscrewed tension is released, and parts may be projected through the air with considerable force.

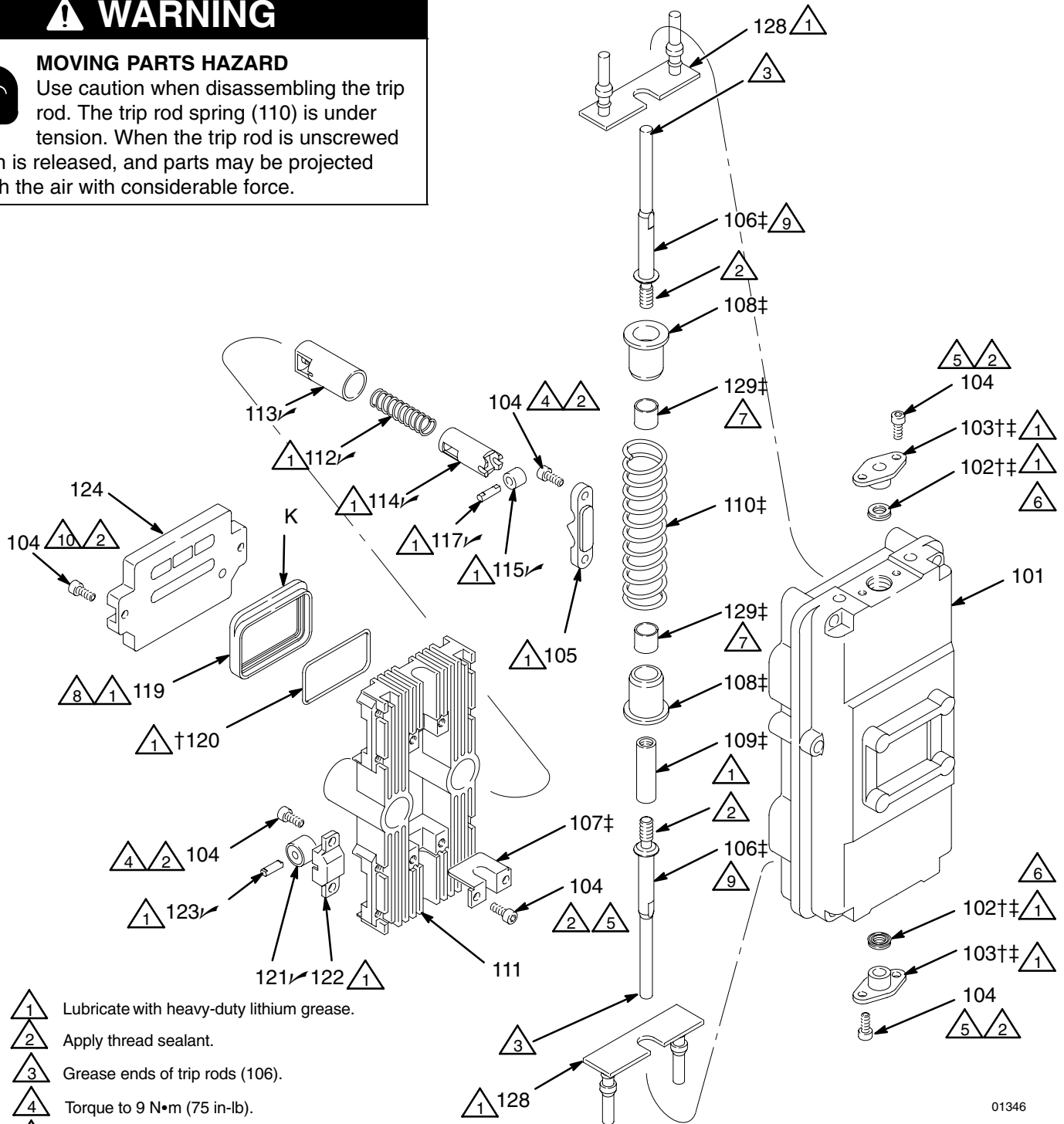

- 1 Lubricate with heavy-duty lithium grease.
- 2 Apply thread sealant.
- 3 Grease ends of trip rods (106).
- 4 Torque to 9 N•m (75 in-lb).
- 5 Torque to 2-3 N•m (20-30 in-lb).
- 6 Lips must face into the housing (101).
- 7 Press fit flush with the inside surface of the guide (108).
- 8 Lip (K) must face toward the nearest end of the carriage (111).
- 9 Torque to 17-23 N•m (150-200 in-lb).
- 10 Torque to 9 N•m (75 in-lb) and unscrew as needed for plates (124) to be flush with housing (101).

† These parts are included in Air Valve Repair Kit 222959, which may be purchased separately.

‡ These parts are included in Trip Rod Kit 222981, which may be purchased separately. The kit also includes the assembled trip rod.

✓ These parts are included in Detent Kit 222982, which may be purchased separately.

01346

Fig. 8

Service

Subplate and Rocker Assemblies

NOTE: Air Valve Repair Kit 222959 is available. Parts included in the kit are marked with a symbol (†). For the best results, use all the parts in the kit.

Disassembly

WARNING

To reduce the risk of serious injury whenever you are instructed to relieve pressure, always follow the **Pressure Relief Procedure** on page 10.

1. Stop the pump at the middle of its stroke. Relieve the pressure before performing any service.
2. Follow the steps under **Air Motor Shroud Disassembly** on page 11.
3. Use an allen wrench to remove the six socket screws (28) holding the air valve (25) to the subplate (23). See Fig. 3 on page 12. Remove the air valve.

NOTE: To replace or service the air valve, refer to pages 11–16.

4. Remove the gasket (26) and the two seals (27). Inspect these parts for wear or damage.
5. Remove the two screws (13) and washers (51) holding the bottom cover (61) to the bottom rocker arm cover (62). See Fig. 9.
6. Remove the pad (63, see Fig. 3 on page 12) from the top rocker assembly. Hold the stud (30) with a wrench while unscrewing the nut (33). Pull the stud (30) out and disassemble the rocker assembly. Push the sleeve (31) out of the rocker arm (29). Inspect the rocker arm, sleeve, and bearings (32) for wear.
7. Disassemble the bottom rocker assembly as explained in step 6.
8. Using a 17 mm box wrench, remove the capscrew (43) and gasket (47) holding the exhaust manifold (45) to the subplate (23). Remove the two liners (44) from the cavities in the manifold. Check that the vertical slot (V) in the manifold is clear of dirt or blockage; clean with a brush or compressed air. See Fig. 9.
9. Using an allen wrench, unscrew the eight socket screws (41) holding the subplate (23) to the cylinder (1). Remove the subplate and the gasket (24). Inspect these parts for wear or damage.

10. Remove the two screws (42), the top rod fitting (20), and the push rod (19) from the motor cap (2). Using an o-ring pick, pull out the seal (21). Inspect these parts for wear. Repeat for the bottom push rod assembly.

Reassembly

1. Lubricate the seal (21†) and insert it in the motor cap (2) with the lips **facing into the cap**. Install the rod fitting (20†). Grease the end of the push rod (19) and insert it in the fitting. Apply thread sealant and torque the screws (42) to 2–3 N•m (20–30 in-lb). Repeat for the bottom push rod assembly. See Fig. 9.
2. Place the gasket (24) on the back side of the subplate (23), aligning the holes in both parts. With the air inlet port (P) facing up, install the subplate on the cylinder (1) with the eight socket screws (41). Torque to 10–12 N•m (90–110 in-lb).
3. Install the two liners (44) in the cavities of the exhaust manifold (45). Attach the manifold to the subplate with the gasket (47) and capscrew (43), using a 17 mm box wrench. Torque to 24–27 N•m (18–20 ft-lb).
4. Lubricate the sleeve (31) and two bearings (32) and install them in the rocker arm (29). Position the rocker arm between the top flanges of the subplate (23).
5. Note that the rocker arm cover (62) has two tabs that are off-center. Install the cover so the end with the two tabs is toward the outside of the subplate (see Fig. 9). Insert the stud (30) through the cover and rocker arm, then install the nut (33). Torque to 22–23 N•m (195–205 in-lb). Replace the rocker arm cover pad (63, see Fig. 3 on page 12).
6. Assemble the bottom rocker assembly as explained in steps 4 and 5. Install the bottom cover (61) and secure to the rocker arm cover with the two screws (13) and washers (51).
7. Install the two seals (27†) and the gasket (26†). See the Detail in Fig. 3 on page 12.
8. Install the air valve (25), using a 6 mm allen wrench and six socket screws (28). Torque to 22–23 N•m (195–205 in-lb).
9. Follow the steps under **Air Motor Shroud Reassembly** on page 11.

Service

† These parts are included in Air Valve Repair Kit 222959, which may be purchased separately.

◆ These parts are included in Premier Cylinder Rebuild Kit 16P239, which may be purchased separately.

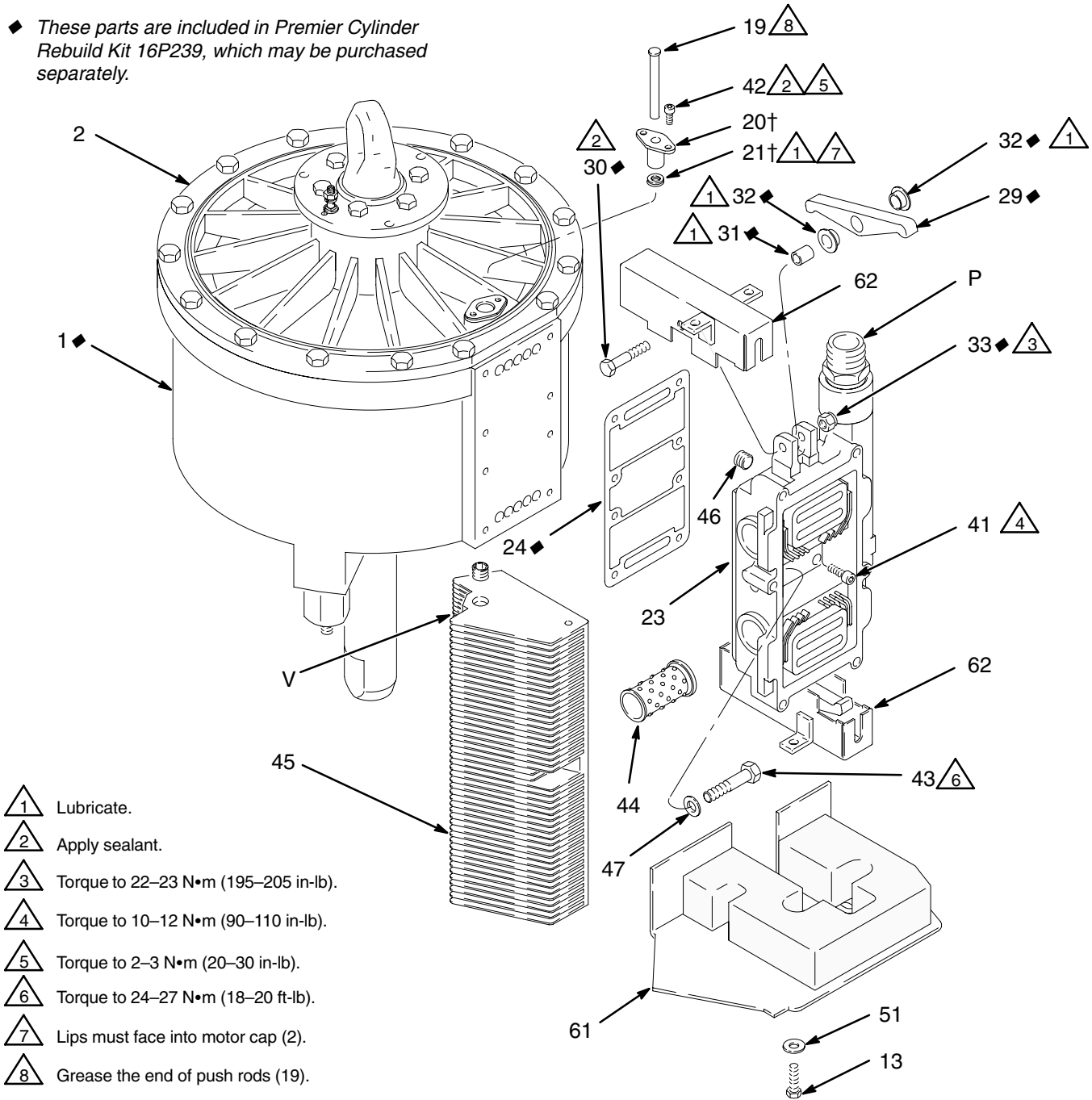

- △1 Lubricate.
- △2 Apply sealant.
- △3 Torque to 22–23 N•m (195–205 in-lb).
- △4 Torque to 10–12 N•m (90–110 in-lb).
- △5 Torque to 2–3 N•m (20–30 in-lb).
- △6 Torque to 24–27 N•m (18–20 ft-lb).
- △7 Lips must face into motor cap (2).
- △8 Grease the end of push rods (19).

Fig. 9

06550A

Service

Piston and Piston Rod Seals

NOTE: Air Motor Repair Kit 222958 is available. Parts included in the kit are marked with an asterisk (*). For the best results, use all the parts in the kit.

Disassembly

WARNING

To reduce the risk of serious injury whenever you are instructed to relieve pressure, always follow the **Pressure Relief Procedure** on page 10.

1. Stop the pump at the middle of its stroke. Relieve the pressure before performing any service.
2. Follow the steps under **Air Motor Shroud Disassembly** on page 11.
3. Disassemble the subplate and rocker assemblies, as explained on page 17.
4. Remove the six screws (13), the lift ring (3), and the o-ring (11*). See Fig. 10.
5. Using a 17 mm socket wrench, remove the fifteen capscrews (12) holding the motor cap (2) to the cylinder (1). Lift the motor cap off the cylinder. Remove and inspect the o-ring (10).
6. Disconnect the air motor from the displacement pump (see your separate pump manual). Leave the adapter (R) attached to the piston rod.
7. Using a rubber mallet, drive the piston assembly (5) out of the cylinder (1). Do not use a hammer.
8. Remove and inspect the piston o-ring (9*). Check the piston and piston rod for scoring or damage. Leave the piston rod and adapter (R) assembled unless any of these parts requires replacement.
9. *If it is necessary to disassemble the adapter (R) from the piston rod, be careful not to scratch the piston rod. Using adjustable wrenches on the flats of the piston rod, unscrew it from the adapter (R).*
10. Remove the screws (14) and the bottom support bracket (35). Press the bearing (6), o-ring (11*), seal (7*) and wiper (8*) out the bottom of the cylinder (1). Inspect these parts for wear or damage.
11. Check the inner surface of the cylinder (1) for scoring or other damage.

Reassembly

1. Lubricate the ID of the cylinder (1), using a rag soaked in grease. See Fig. 10.
2. Lubricate the seals and o-ring (7*, 8*, 11*). The bottom of the bearing (6) has a narrow o-ring groove on the outer surface. Install the o-ring (11*) in this groove. Install the wiper (8*) in the bearing, so the notch of the wiper faces down, out of the bearing. At the top of the bearing, install the seal (7*) so the lips face up, toward the cylinder (1).
3. Press the bearing assembly into the neck of the cylinder (1) from the bottom until it is seated.
4. Install the bottom support bracket (35). Apply thread sealant to the screws (14) and torque to 6–7 N•m (55–65 in-lb).
5. If the adapter (R) was disassembled, screw the piston rod onto the adapter (R). Using adjustable wrenches on the flats of the piston rod, torque to 318–349 N•m (234–257 ft-lb).
6. Lubricate the o-ring (9*) and install it on the piston (5).
7. Lubricate the piston rod. Lower the piston assembly into the cylinder (1), carefully sliding the adapter and rod down through the bearing (6).
8. Reconnect the air motor to the displacement pump (see your separate pump manual).
9. Lubricate the o-ring (10) and install it on the motor cap (2). Place the motor cap on the cylinder (1) so the push rod hole (M) is aligned with the flat surface (F) of the cylinder. Attach the cap with the fifteen capscrews (12), using a 17 mm socket wrench. Torque to 39–43 N•m (29–32 ft-lb).
10. Lubricate the o-ring (11*) and install it on the underside of the lift ring (3). Align the lift ring with the six inner holes in the motor cap, with the grounding lug (49) positioned as shown. Apply thread sealant and install the six screws (13).
11. Reassemble the subplate and rocker assemblies, as explained on page 17.
12. Follow the steps under **Air Motor Shroud Reassembly** on page 11.

Service

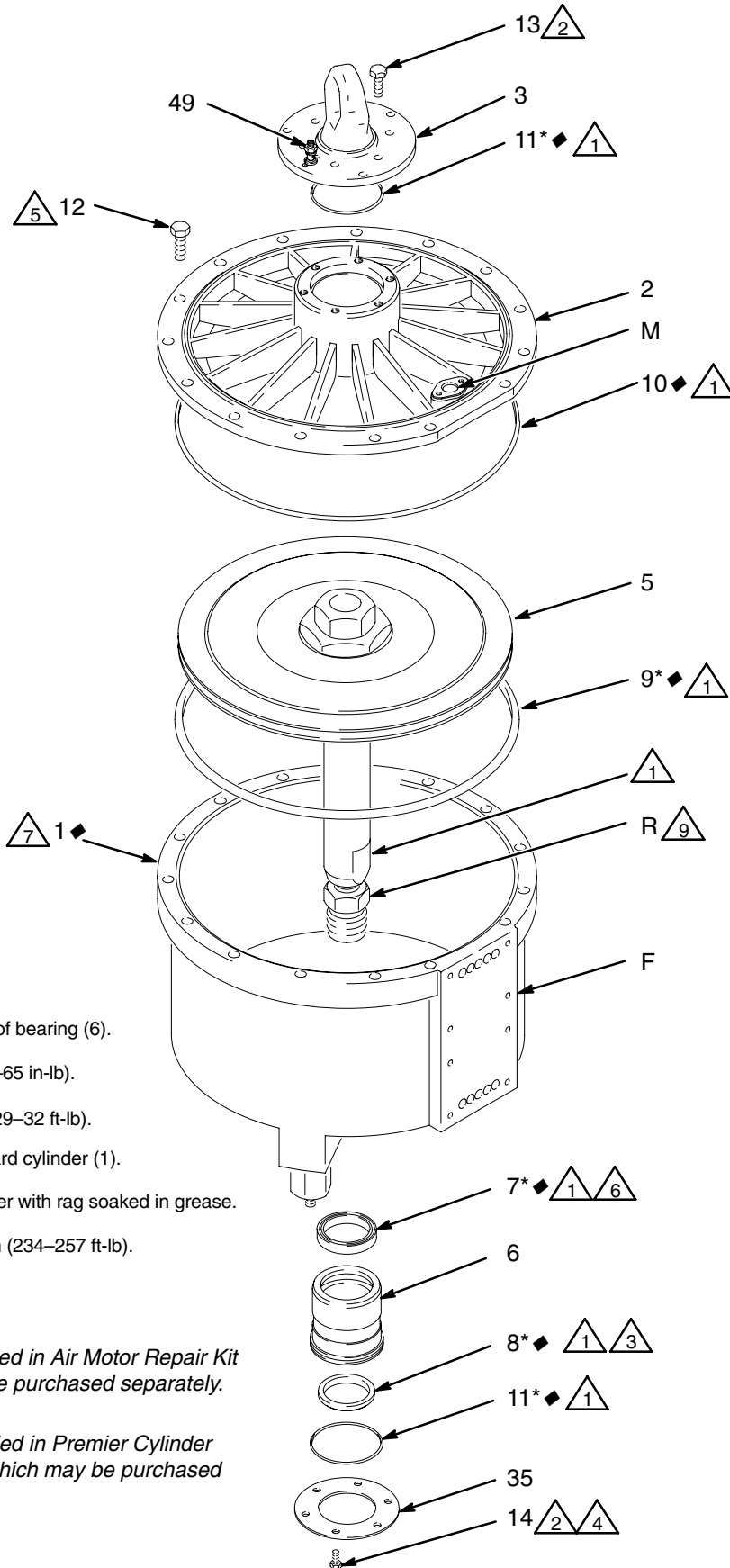

- Lubricate.
- Apply sealant.
- Notch faces down, out of bearing (6).
- Torque to 6–7 N•m (55–65 in-lb).
- Torque to 39–43 N•m (29–32 ft-lb).
- Lips must face up, toward cylinder (1).
- Lubricate inside diameter with rag soaked in grease.
- Torque to 318–349 N•m (234–257 ft-lb).

* These parts are included in Air Motor Repair Kit 222958, which may be purchased separately.

◆ These parts are included in Premier Cylinder Rebuild Kit 16P239, which may be purchased separately.

Fig. 10

06551A

Parts

Model 222800 Premier Air Motor, Series C

NOTE: Some parts of this assembly are listed and pictured on page 22.

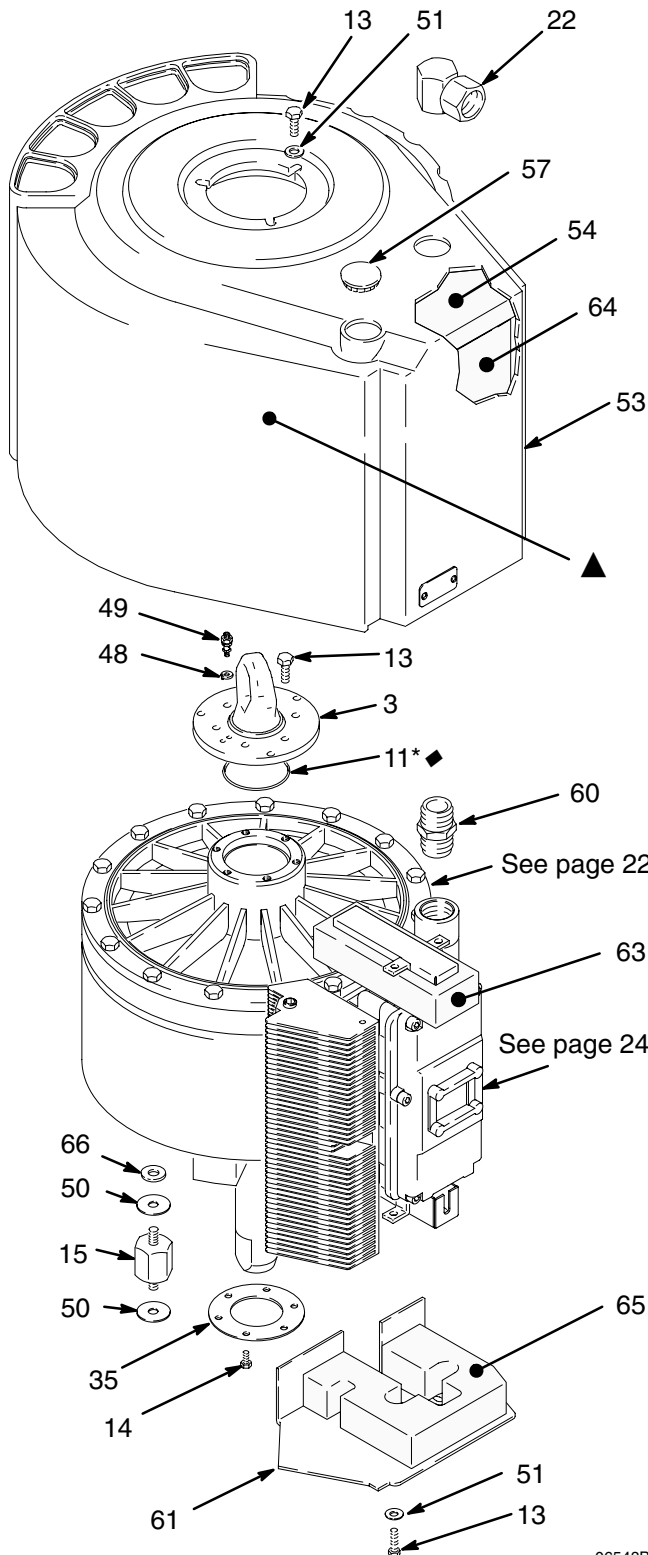

Ref. No.	Part No.	Description	Qty.
3	184353	RING, lift	1
11*	109484	O-RING; buna-N	1
13	107558	SCREW, cap, hex hd; M8 x 1.25; 25 mm (0.98 in.) long	11
14	105468	SCREW, cap, hex hd; M6 x 1; 12 mm (0.47 in.) long	6
15	189977	MOUNT; 3/8-16 unc-2A	3
22	112955	SWIVEL, air inlet, 90°; 1 in. npt(f) x 1 in. npsm(f)	1
35	191989	BRACKET, support	1
48	104582	WASHER, grounding	1
49	104029	LUG, grounding	1
50	190072	GASKET; polyethylene	6
51	108788	WASHER, flat; 8 mm	5
53	276457	SHROUD, motor	1
54	113918	PAD, top	1
57	111909	PLUG, button	1
60	158585	NIPPLE; 1 in. npt	1
61	120027	COVER, bottom	1
63	192881	PAD, rocker arm cover	1
64	192883	PAD, front	1
65	192882	PAD, bottom	1
66	100132	WASHER, flat	3

* These parts are included in Air Motor Repair Kit 222958, which may be purchased separately.

◆ These parts are included in Premier Cylinder Rebuild Kit 16P239, which may be purchased separately.

▲ Foreign language warning labels are available at no cost. Order Part No. 290396 (German), 290397 (French), or 290398 (Spanish).

06548B

Parts

NOTE: Some parts of this assembly are listed and pictured on page 21.

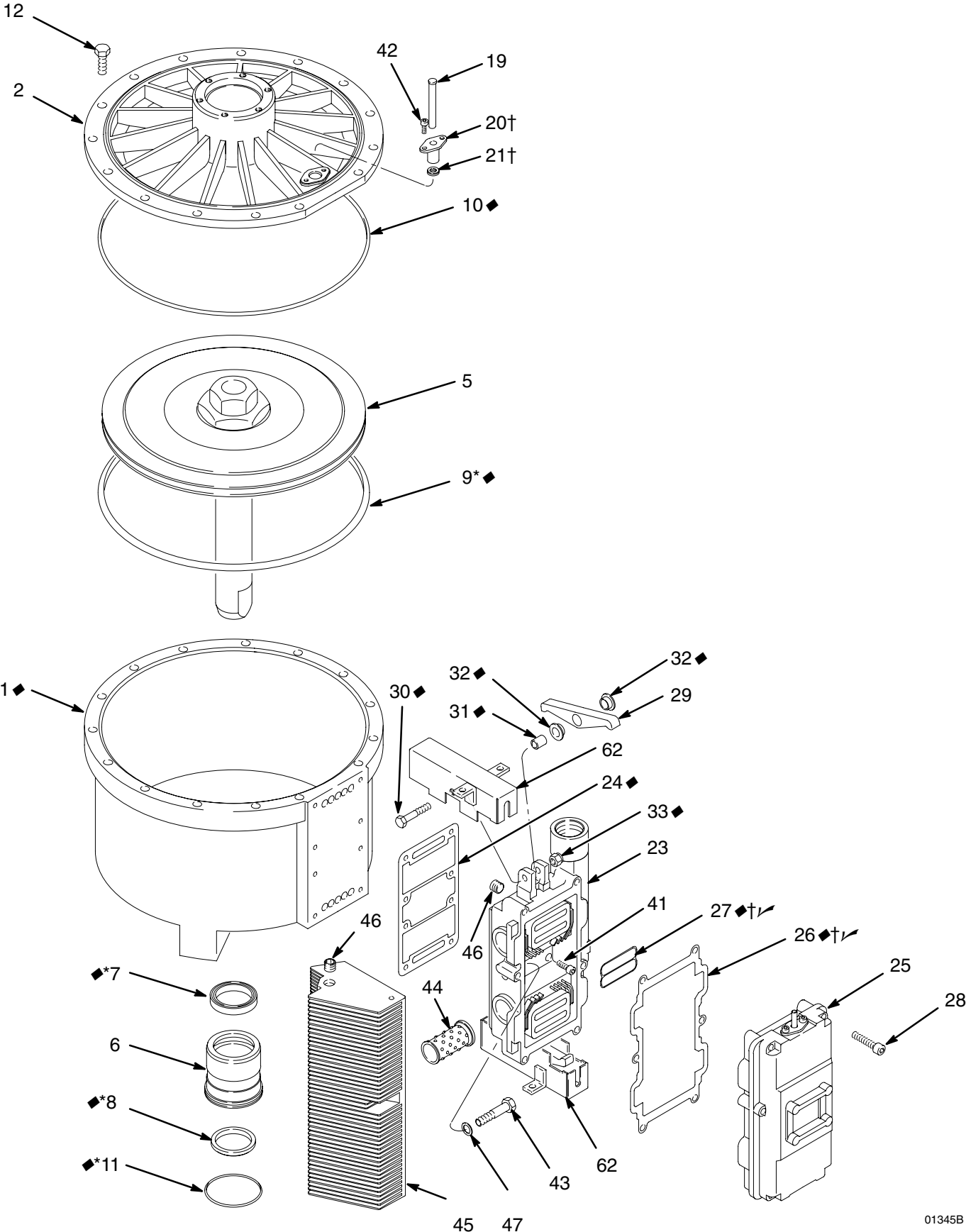

01345B

Parts

Model 222800 Premier Air Motor, Series C (shown)

NOTE: Some parts of this assembly are listed and pictured on page 21.

Ref. No.	Part No.	Description	Qty.	Ref. No.	Part No.	Description	Qty.
1 ◆	120026	CYLINDER, motor	1	33 ◆	105329	NUT, lock, with nylon insert; M8 x 1.25	2
2	184374	CAP, motor	1	41	109489	SCREW, cap, socket hd; M6 x 1.0; 20 mm (0.79 in.) long	8
5	15B959	PISTON ASSEMBLY	1	42	107100	SCREW, cap, socket hd; M5 x 0.8; 12 mm (0.47 in.) long	4
6	184351	BEARING; acetal	1	43	109491	SCREW, cap, hex hd; M10 x 1.5; 50 mm (1.97 in.) long	1
7* ◆	109492	SEAL, bearing; polyurethane	1	44	276076	LINER; polyurethane	2
8* ◆	109493	WIPER; polyurethane	1	45	186264	MANIFOLD, exhaust	1
9* ◆	109485	O-RING; buna-N	1	46	100721	PLUG, pipe, socket hd; 1/4–18 npt	3
10 ◆	109486	O-RING; buna-N	1	47	167730	GASKET, copper	1
11* ◆	109484	O-RING; buna-N	1	62	192686	COVER, rocker arm	2
12	109487	SCREW, cap, hex hd; M10 x 1.5; 30 mm (1.18 in.) long	15				
19	184357	ROD, push	2				
20 †	276066	FITTING, rod	2				
21 †	109494	SEAL, rod; polyurethane	2				
23	184463	SUBPLATE	1				
24 ◆	184376	GASKET; cork/rubber	1				
25	222799	VALVE, air motor; see page 24	1				
26 †/✓ ◆	184377	GASKET; cork/rubber	1				
27 †/✓ ◆	184467	SEAL; buna-N	2				
28	109490	SCREW, cap, socket hd; M8 x 1.25; 50 mm (1.97 in.) long	6				
29 ◆	184359	ARM, rocker	2				
30 ◆	110036	STUD	2				
31 ◆	184607	SLEEVE, rocker arm	2				
32 ◆	184360	BEARING, rocker; acetal	4				

* *These parts are included in Air Motor Repair Kit 222958, which may be purchased separately.*

† *These parts are included in Air Valve Repair Kit 222959, which may be purchased separately.*

✓ *These parts are included in Detent Kit 222982, which may be purchased separately.*

◆ *These parts are included in Premier Cylinder Rebuild Kit 16P239, which may be purchased separately.*

NOTE: Remote Exhaust Manifold (184559) is available with a 1 in. npt(f) outlet

Parts

Part No. 222799 Air Valve, Series A

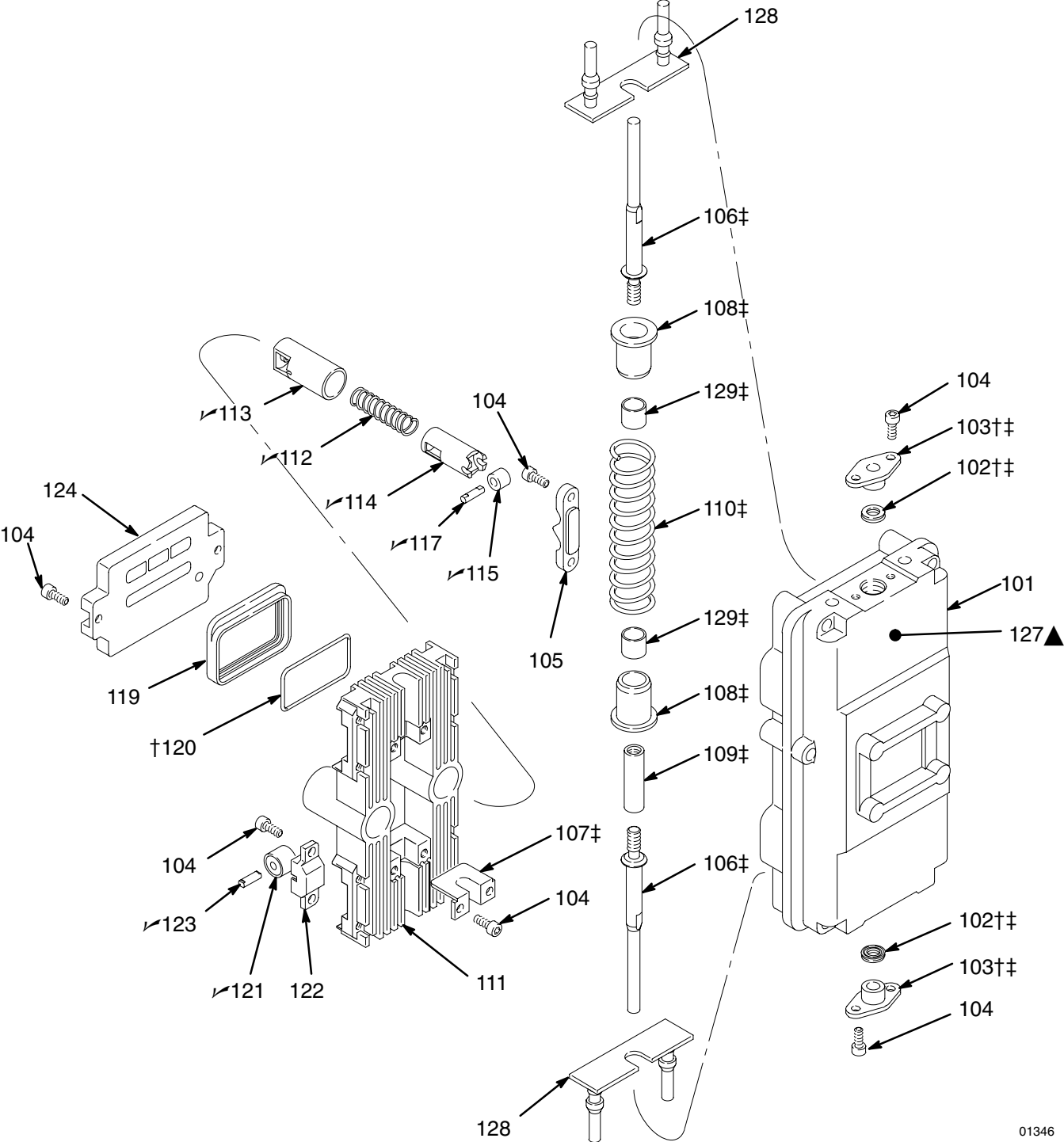

01346

Parts

Part No. 222799 Air Valve, Series A

Ref. No.	Part No.	Description	Qty.	Ref. No.	Part No.	Description	Qty.
101	184375	HOUSING, valve	1	121✓	109513	ROLLER, bearing	4
102†‡	109494	SEAL, rod; polyurethane	2	122	276068	RETAINER, bearing	4
103†‡	276067	FITTING, rod; acetal	2	123✓	184605	PIN, roller	4
104	107100	SCREW, cap, socket hd; M5 x 0.8; 12 mm (0.47 in.) long	24	124	184362	PLATE, slide	2
105	276060	PLATE, detent	2	127▲	184614	LABEL, caution	2
106‡	184358	ROD, trip	2	128	184615	BUMPER	2
107‡	276083	BEARING; acetal	2	129‡	184603	BEARING, guide; acetal	2
108‡	184361	GUIDE, spring	2	† <i>These parts are included in Air Valve Repair Kit 222959, which may be purchased separately.</i>			
109‡	184465	SHAFT	1	‡ <i>These parts are included in Trip Rod Kit 222981, which may be purchased separately.</i>			
110‡	184485	SPRING, compression	1	✓ <i>These parts are included in Detent Kit 222982, which may be purchased separately.</i>			
111	184372	CARRIAGE, valve	1	▲ <i>Replacement Danger and Warning labels, tags and cards are available at no cost.</i>			
112✓	184484	SPRING, compression	2				
113✓	276064	GUIDE, plunger; acetal	2				
114✓	184370	PLUNGER	2				
115✓	184619	ROLLER, detent	2				
117✓	184369	PIN, roller	2				
119	184363	BLOCK, slide	2				
120†	109514	O-RING; urethane	2				

Technical Data

Category	Data
Maximum air input pressure	0.7 MPa, 7 bar (100 psi)
Operating pressure range	.07–0.7 MPa, 0.7–7 bar (10–100 psi)
Maximum recommended speed	50 cycles per min
Operating temperature	12.8 to 65.6°C (55 to 150°F)
Air motor piston effective area	800 cm ² (124 in. ²)
Air motor piston diameter	321 mm (12.64 in.)
Stroke length	120 mm (4.75 in.)
Air inlet size	1 npsm(f)
Weight	approx. 50 kg (110 lb)

Dimensions

Top View

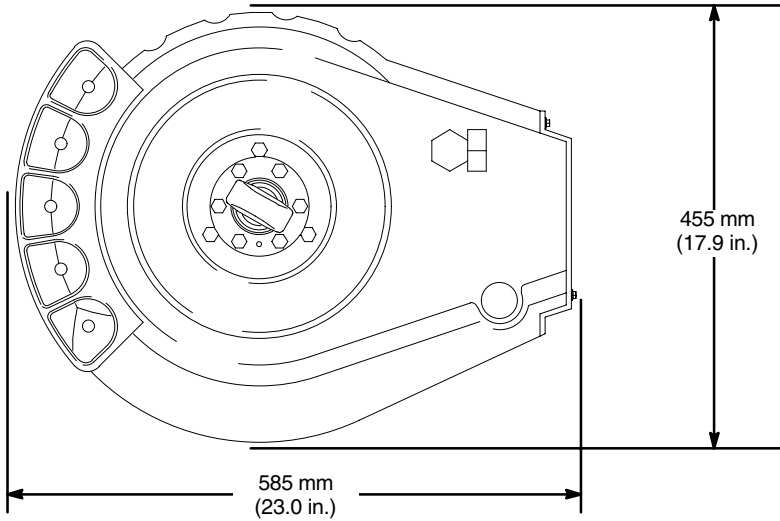

06554

Side View

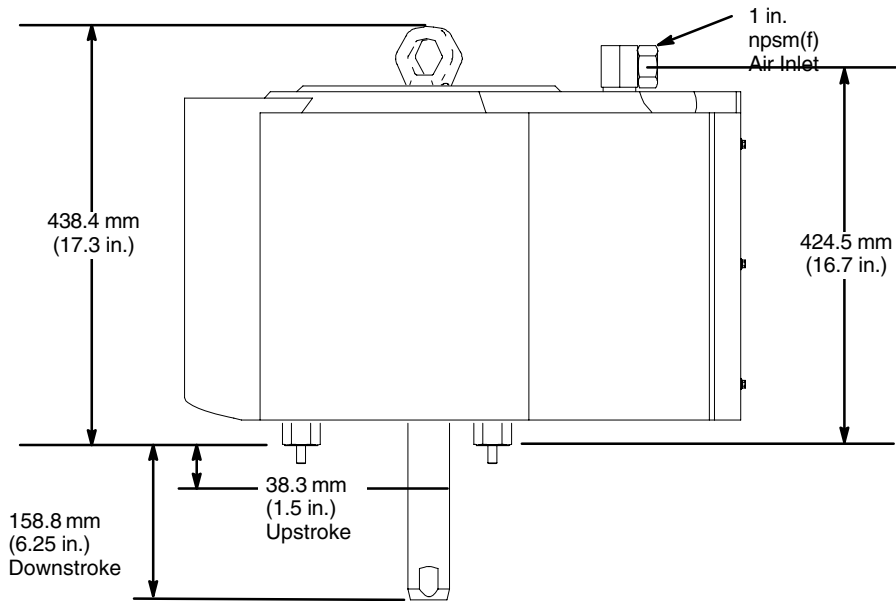

06553

Bottom View

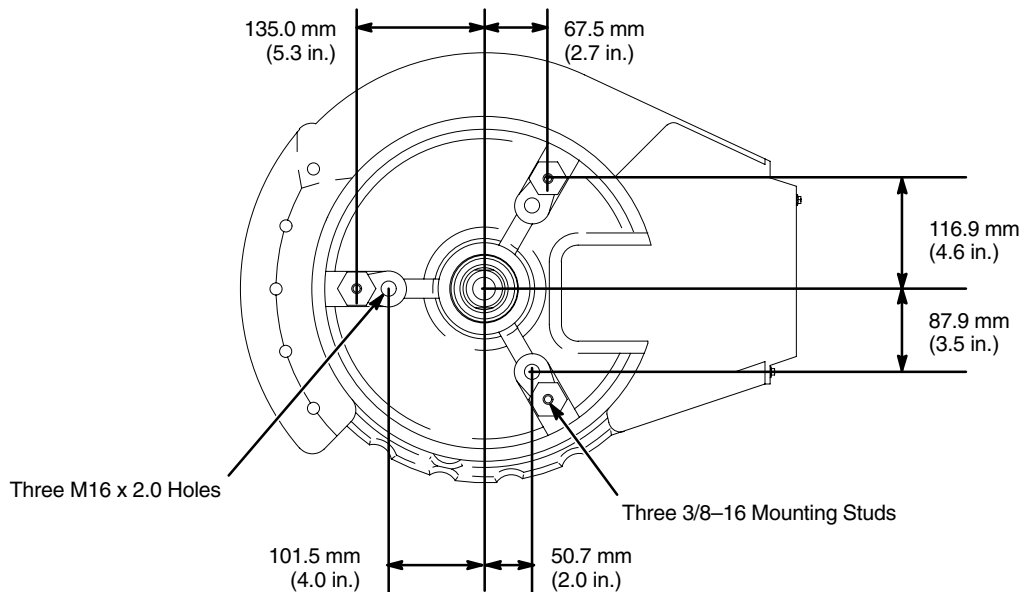

06555

Graco Standard Warranty

Graco warrants all equipment manufactured by Graco and bearing its name to be free from defects in material and workmanship on the date of sale to the original purchaser for use. With the exception of any special, extended, or limited warranty published by Graco, Graco will, for a period of twelve months from the date of sale, repair or replace any part of the equipment determined by Graco to be defective. This warranty applies only when the equipment is installed, operated and maintained in accordance with Graco's written recommendations.

This warranty does not cover, and Graco shall not be liable for general wear and tear, or any malfunction, damage or wear caused by faulty installation, misapplication, abrasion, corrosion, inadequate or improper maintenance, negligence, accident, tampering, or substitution of non-Graco component parts. Nor shall Graco be liable for malfunction, damage or wear caused by the incompatibility of Graco equipment with structures, accessories, equipment or materials not supplied by Graco, or the improper design, manufacture, installation, operation or maintenance of structures, accessories, equipment or materials not supplied by Graco.

This warranty is conditioned upon the prepaid return of the equipment claimed to be defective to an authorized Graco distributor for verification of the claimed defect. If the claimed defect is verified, Graco will repair or replace free of charge any defective parts. The equipment will be returned to the original purchaser transportation prepaid. If inspection of the equipment does not disclose any defect in material or workmanship, repairs will be made at a reasonable charge, which charges may include the costs of parts, labor, and transportation.

THIS WARRANTY IS EXCLUSIVE, AND IS IN LIEU OF ANY OTHER WARRANTIES, EXPRESS OR IMPLIED, INCLUDING BUT NOT LIMITED TO WARRANTY OF MERCHANTABILITY OR WARRANTY OF FITNESS FOR A PARTICULAR PURPOSE.

Graco's sole obligation and buyer's sole remedy for any breach of warranty shall be as set forth above. The buyer agrees that no other remedy (including, but not limited to, incidental or consequential damages for lost profits, lost sales, injury to person or property, or any other incidental or consequential loss) shall be available. Any action for breach of warranty must be brought within two (2) years of the date of sale.

Graco makes no warranty, and disclaims all implied warranties of merchantability and fitness for a particular purpose in connection with accessories, equipment, materials or components sold but not manufactured by Graco. These items sold, but not manufactured by Graco (such as electric motors, switches, hose, etc.), are subject to the warranty, if any, of their manufacturer. Graco will provide purchaser with reasonable assistance in making any claim for breach of these warranties.

In no event will Graco be liable for indirect, incidental, special or consequential damages resulting from Graco supplying equipment hereunder, or the furnishing, performance, or use of any products or other goods sold hereto, whether due to a breach of contract, breach of warranty, the negligence of Graco, or otherwise.

FOR GRACO CANADA CUSTOMERS

The parties acknowledge that they have required that the present document, as well as all documents, notices and legal proceedings entered into, given or instituted pursuant hereto or relating directly or indirectly hereto, be drawn up in English. Les parties reconnaissent avoir convenu que la rédaction du présente document sera en Anglais, ainsi que tous documents, avis et procédures judiciaires exécutés, donnés ou intentés à la suite de ou en rapport, directement ou indirectement, avec les procédures concernées.

Graco Information

TO PLACE AN ORDER, contact your Graco distributor, or call one of the following numbers to identify the distributor closest to you:

1-800-328-0211 Toll Free
612-623-6921
612-378-3505 Fax

All written and visual data contained in this document reflects the latest product information available at the time of publication. Graco reserves the right to make changes at any time without notice.

For patent information, see www.graco.com/patents.

Original instructions. This manual contains English. MM 308213

Graco Headquarters: Minneapolis
International Offices: Belgium, China, Japan, Korea

GRACO INC. AND SUBSIDIARIES • P.O. BOX 1441 • MINNEAPOLIS MN 55440-1441 • USA
Copyright 1993, Graco Inc. All Graco manufacturing locations are registered to ISO 9001.

www.graco.com
Revision V, March 2014