

# Instructions–Parts List

 SPRAY-QUIP, INC.  
1754 DES JARDINES ST.  
HOUSTON, TX 77023  
PH.: 713-923-2771  
WWW.SPRAYQUIP.COM



## 7 in. (178 mm) DIAMETER **Bulldog<sup>®</sup> Air Motor**

307049Y

ENG

*100 psi (0.7 MPa, 7 bar) Maximum Air Input Pressure*



**Important Safety Instructions**  
Read all warnings and instructions in this manual.  
Save these instructions.

### **Model 208356, Series J**

Standard Air Motor for most Bulldog<sup>®</sup> Pumps

### **Model 625794, Series A**

For Bulldog<sup>®</sup> Sanitary Pumps

### **Model 208357, Series J**

For Bulldog<sup>®</sup> transfer pumps

### **Model 902098, Series A**

For VRHM pumps

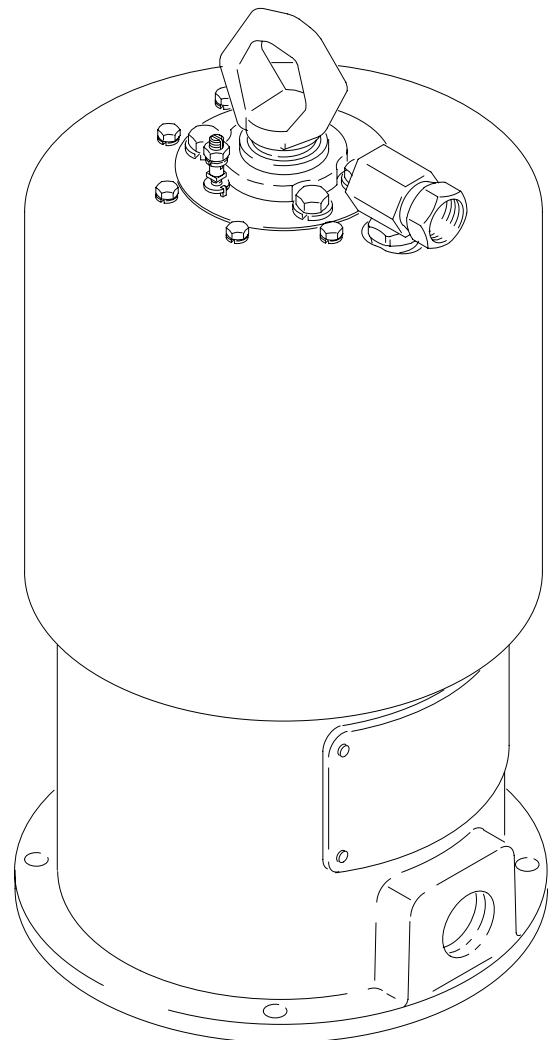

03330

**Model 208356 Shown**

# Table of Contents

Warnings .....	2	Technical Data .....	26
Installation .....	5	Dimensions .....	27
Operation .....	6	Mounting Hole Layout .....	27
Troubleshooting .....	7	Warranty .....	28
Service .....	8	Graco Information .....	28
Parts			
Model 208356, 902098 .....	20		
Model 208357 .....	22		
Model 625794 .....	24		

## Symbols

### Warning Symbol



This symbol alerts you to the possibility of serious injury or death if you do not follow the instructions.

### Caution Symbol



This symbol alerts you to the possibility of damage to or destruction of equipment if you do not follow the instructions.

## ⚠ WARNING



INSTRUCTIONS

### EQUIPMENT MISUSE HAZARD

Equipment misuse can cause the equipment to rupture or malfunction and result in serious injury.

- This equipment is for professional use only.
- Read all instruction manuals, tags, and labels before operating the equipment.
- Use the equipment only for its intended purpose. If you are uncertain about usage, call your Graco distributor.
- Do not alter or modify this equipment. Use only genuine Graco parts and accessories.
- Check equipment daily. Repair or replace worn or damaged parts immediately.
- Do not exceed the maximum working pressure stated on the equipment or in the **Technical Data** for your equipment. Do not exceed the maximum working pressure of the lowest rated component in your system.
- Use fluids and solvents which are compatible with the equipment wetted parts. Refer to the **Technical Data** section of all equipment manuals. Read the fluid and solvent manufacturer's warnings.
- Do not use hoses to pull equipment.
- Route hoses away from traffic areas, sharp edges, moving parts, and hot surfaces. Do not expose Graco hoses to temperatures above 180°F (82°C) or below -40°F (-40°C).
- Wear hearing protection when operating this equipment.
- Do not lift pressurized equipment.
- Do not lift the equipment by the air motor lift ring if the total weight of the equipment exceeds 550 lb (250 kg).
- Comply with all applicable local, state, and national fire, electrical, and safety regulations.

# WARNING



## SKIN INJECTION HAZARD

Spray from the gun, hose leaks, or ruptured components can inject fluid into your body and cause extremely serious injury, including the need for amputation. Fluid splashed in the eyes or on the skin can also cause serious injury.



- Fluid injected into the skin might look like just a cut, but it is a serious injury. **Get immediate medical attention.**
- Do not point the gun at anyone or at any part of the body.
- Do not put your hand or fingers over the spray tip.
- Do not stop or deflect leaks with your hand, body, glove or rag.
- Do not “blow back” fluid; this is not an air spray system.
- Always have the tip guard and the trigger guard on the gun when spraying.
- Check the gun diffuser operation weekly. Refer to the gun manual.
- Be sure the gun trigger safety operates before spraying.
- Lock the gun trigger safety when you stop spraying.
- Follow the **Pressure Relief Procedure** on page 6 whenever you: are instructed to relieve pressure; stop spraying; clean, check, or service the equipment; and install or clean the spray tip.
- Tighten all fluid connections before operating the equipment.
- Check the hoses, tubes, and couplings daily. Replace worn, damaged, or loose parts immediately. Permanently coupled hoses cannot be repaired; replace the entire hose.
- Use only Graco approved hoses. Do not remove any spring guard that is used to help protect the hose from rupture caused by kinks or bends near the couplings.



## MOVING PARTS HAZARD

Moving parts, such as the air motor piston, can pinch or amputate your fingers.

- Keep clear of all moving parts when starting or operating the pump.
- Before servicing the equipment, follow the **Pressure Relief Procedure** on page 6 to prevent the equipment from starting unexpectedly.

# WARNING



## FIRE AND EXPLOSION HAZARD

Improper grounding, poor ventilation, open flames or sparks can cause a hazardous condition and result in a fire or explosion and serious injury.

- Ground the equipment and the object being sprayed. Refer to **Grounding** on page 5.
- If there is any static sparking or you feel an electric shock while using this equipment, **stop spraying immediately**. Do not use the equipment until you identify and correct the problem.
- Provide fresh air ventilation to avoid the buildup of flammable fumes from solvents or the fluid being sprayed.
- Keep the spray area free of debris, including solvent, rags, and gasoline.
- Electrically disconnect all equipment in the spray area.
- Extinguish all open flames or pilot lights in the spray area.
- Do not smoke in the spray area.
- Do not turn on or off any light switch in the spray area while operating or if fumes are present.
- Do not operate a gasoline engine in the spray area.



## TOXIC FLUID HAZARD

Hazardous fluid or toxic fumes can cause serious injury or death if splashed in the eyes or on the skin, inhaled, or swallowed.

- Know the specific hazards of the fluid you are using.
- Store hazardous fluid in an approved container. Dispose of hazardous fluid according to all local, state and national guidelines.
- Always wear protective eyewear, gloves, clothing and respirator as recommended by the fluid and solvent manufacturer.

# Installation

## General Information

**NOTE:** Reference numbers and letters in parentheses in the text refer to the callouts in the figures and the parts drawing.

**NOTE:** Always use Genuine Graco Parts and Accessories, available from your Graco distributor.

## Grounding

**⚠ WARNING**

**FIRE AND EXPLOSION HAZARD**  
Before operating the pump, ground the system as explained below. Also read the section **FIRE AND EXPLOSION HAZARD** on page 4.



1. *Pump:* use a ground wire and clamp as shown in Fig. 1. Loosen the grounding lug locknut (W) and washer (X). Insert one end of a 12 ga (1.5 mm<sup>2</sup>) minimum ground wire (Y) into the slot in lug (Z) and tighten the locknut securely. Connect the other end of the wire to a true earth ground. Order Part No. 237569 Grounding Clamp and Wire.
2. *Air and fluid hoses:* use only electrically conductive hoses with a maximum of 500 feet (150 m) combined hose length to ensure grounding continuity. Check the electrical resistance of your air and fluid hoses at least once a week. If the total resistance to ground exceeds 29 megohms, replace the hose immediately.  
  
**NOTE:** Use a meter that is capable of measuring resistance at this level.
3. *Air compressor:* follow manufacturer's recommendations.
4. *Spray gun or dispensing valve:* ground through connection to a properly grounded fluid hose and pump.
5. *Object being sprayed:* follow your local code.

6. *Fluid supply container:* follow your local code.
7. *Solvent pails used when flushing:* follow your local code. Use only metal pails, which are conductive, placed on a grounded surface. Do not place the pail on a nonconductive surface, such as paper or cardboard, which interrupts the grounding continuity.
8. *To maintain grounding continuity when flushing or relieving pressure,* hold a metal part of the spray gun firmly to the side of a grounded *metal* pail, then trigger the gun.

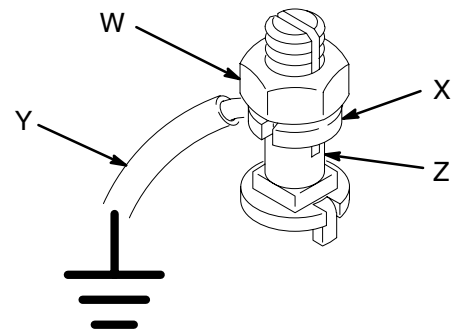

Fig. 1

0864

## Air Motor Icing

Moisture in the compressed air can collect in the air motor and freeze, causing the motor to stall. This is called icing. If icing occurs, shut off the air supply and allow the ice to thaw.

To minimize icing, reduce the moisture in your compressed air supply by using an air dryer or a filter which traps water.

The main air line should slope slightly downward so water will collect at the end of the line, where it can be drained. Additionally, plumb a drop line from the top of each main air line. Install an automatic drain or a drain valve at the bottom of each drop.

For additional help in designing your system, contact your Graco distributor.

# Operation

## Pressure Relief Procedure

### WARNING



#### SKIN INJECTION HAZARD

To reduce the risk of serious injury, including fluid injection, splashing in the eyes or on the skin, or moving parts, always follow the **Pressure Relief Procedure** whenever you:

- are instructed to relieve the pressure,
- shut off the pump
- stop spraying/dispensing,
- check or service any of the system equipment,
- or install or clean the spray tips/nozzle.

1. Lock the gun/valve trigger safety.
2. Turn off the air to the motor.
3. Close the bleed-type master air valve (required in your system).

4. Unlock the gun/valve trigger safety. Hold a metal part of the gun/valve firmly to a grounded metal pail. Trigger the gun/valve to relieve pressure.
5. Lock the gun/valve trigger safety.
6. Open the fluid drain valve. Leave the fluid drain valve open until you are ready to spray/dispense again.

*If you suspect that the spray tip/nozzle or hose is completely clogged, or that pressure has not been fully relieved after following the steps above, **very slowly** loosen the tip guard retaining nut or hose end coupling to relieve pressure gradually, then loosen completely. Now clear the tip/nozzle or hose obstruction.*

## Preventive Maintenance Schedule

The operating conditions of your particular system determine how often maintenance is required. Establish a preventive maintenance schedule by recording when and what kind of maintenance is needed, and then determine a regular schedule for checking your system.

# Troubleshooting

## ⚠ WARNING

Moving parts can pinch or amputate your fingers or other body parts. To reduce the risk of serious injury, including amputation, keep fingers out of the detent housing (45) and exhaust openings.

### Detail of Air Director Valves

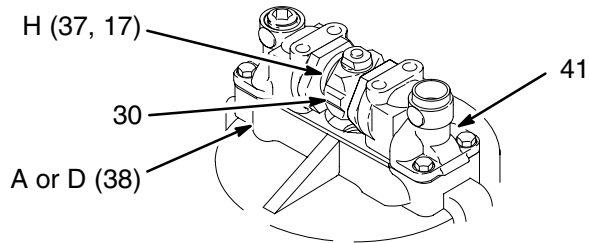

06466

### Model 208356 Shown

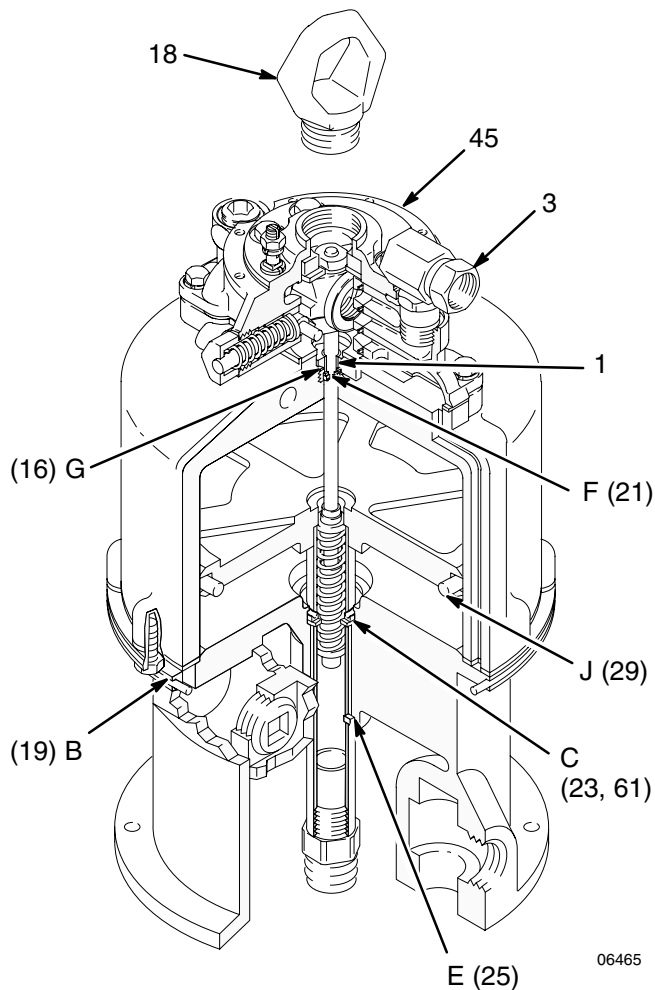

Fig. 2

## Stalled Motor

To restart a stalled motor, remove the lift ring (18) from the detent housing (45) and use a screwdriver to push the air valve housing (30) down. See Fig. 2.

## Locating Air Leaks

To locate an air leak, shut off the air supply and disconnect the air hose. Screw the inlet union (3) out of the air manifold (41). Remove the shield (51), then screw the union back into the manifold. Connect the air hose and turn the air on. Do not exceed 40 psi (0.28 MPa, 2.8 bar) incoming air pressure. Use the checking methods listed below in the Check Chart to find where the air is leaking. Refer to Fig. 2.

### Check Chart

Stroke Position	Fig. Ref. Points	Checking Method	Cause of Leakage
UP only (air valve housing down)	A	By feel	Blown air manifold gaskets (38)
	B	By feel	Blown air cylinder gasket (19)
	C	Squirt oil around wiper seal (25)	Worn throat packings (23 or 61)
DOWN only (air valve housing up)	D	By feel	Blown air manifold gasket (38)
	E	By Feel	Damaged wiper seal (25)
	F	Squirt oil around bearing (1)	Worn trip rod packing (21)
BOTH	G	Squirt oil around bearing (1)	Damaged trip rod bearing gasket (16)
	H	Squirt oil around air valve (30)	Worn air valves (37) or o-rings (17)
	J	Hold paper strip over exhaust holes	Worn piston o-ring (29)

# Service

## ⚠ WARNING



To avoid serious injury and equipment damage, do not lift the equipment by the air motor lift ring if the total weight of the equipment exceeds 550 lb (250 kg). The lift ring cannot support that weight.

**NOTE:** Repair kit 206734 is available. For best results, use all the new parts in the kit, even if the old ones look good. Parts included in the kit are marked with an asterisk, for example (16\*).

**NOTE:** Inspect all parts as they are disassembled and replace any worn or damaged parts.

## Disassembly

## ⚠ WARNING

To reduce the risk of serious injury whenever you are instructed to relieve pressure, always follow the **Pressure Relief Procedure** on page 6.

1. Relieve the pressure.
2. Disconnect the displacement pump. Disconnect the ground wire. Set the motor upright on a workbench.

**NOTE:** Refer to Fig. 3 for steps 3 to 5.

3. Remove the air inlet fitting (3). Remove the screws (10) and lift off the air motor shield (51). Remove the grommet (40).
4. Unscrew the spring retainers (32) and remove the spring (34), guide (33), and plunger (46) from each side of the detent housing (45).
5. Remove the four screws (13) and lockwashers (7) from the detent housing (45). Carefully lift the housing so the rollers (4) and axles (52) do not fall out. Remove the rollers, axles, washer (27), and rubber pad (28).

Model 208356 Shown

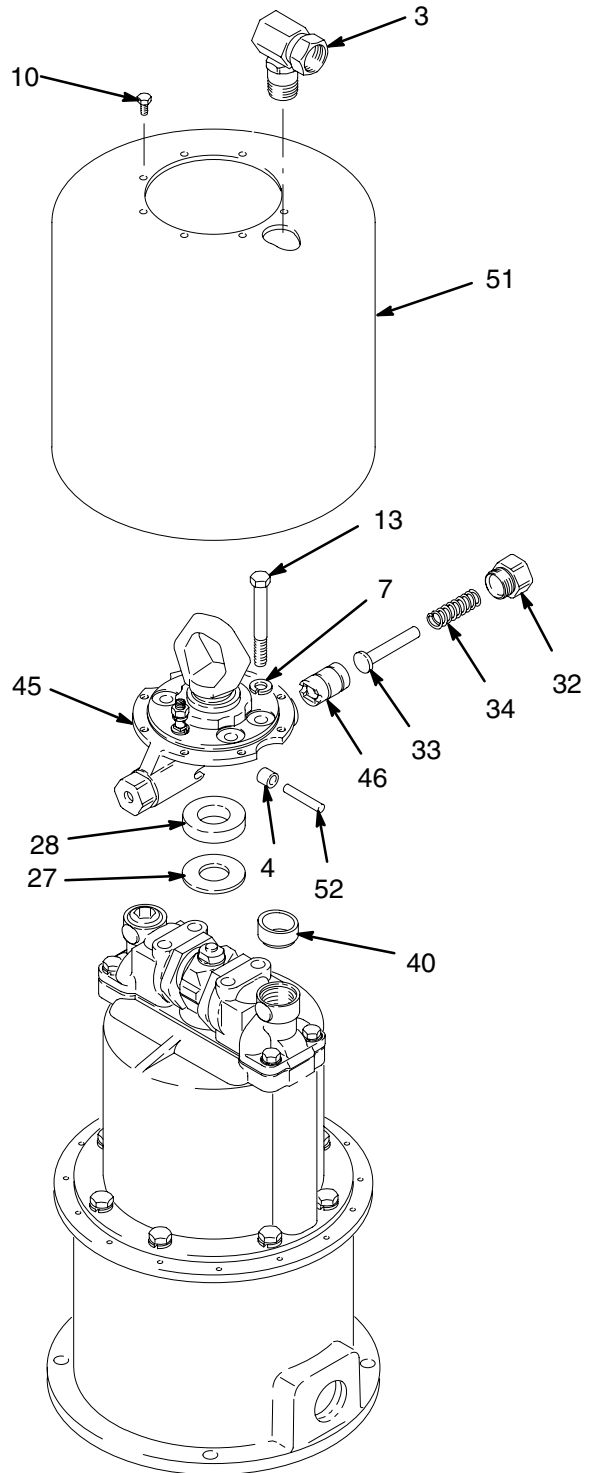

Fig. 3

07268



# Service

**NOTE:** Refer to Fig. 4 for steps 6 to 9.

6. To prevent the spring-loaded director valves (37) from popping out of the air valve housing (30), hold them in with your fingers. Lift the air valve housing and rotate it 90°, so it rests on the manifolds (41). Remove your fingers slowly, allowing the valve springs to release gently. Remove and inspect the director valves (37), o-rings (17), and springs (26).

## **⚠ CAUTION**

Be careful not to damage the surface of the trip rod (22), which would restrict its free movement. Special padded pliers, Part No. 207579, are available.

7. Pull the trip rod (22) up and grasp it with the padded locking pliers (order Part No. 207579) below the hub (35). Hold the flats of the hub with a wrench, screw off the trip rod nut (31), and remove the air valve housing (30). Remove the lockwasher (9) and screw off the hub. Now release the pliers.
8. Remove the two screws (8) and lockwashers (9) from each air manifold (41). Remove the manifolds and gaskets (38) from the cylinder (44).

## **⚠ WARNING**

The openings in the valve plates (47) are very sharp. Be careful not to cut yourself.

9. Remove and check the valve plates (47) for wear or damage, handling them carefully. Clean the plates and mating surfaces of the manifolds (41).

**NOTE:** If you replace the valve plates, also replace the seals (39).

### **Model 208356 Shown**

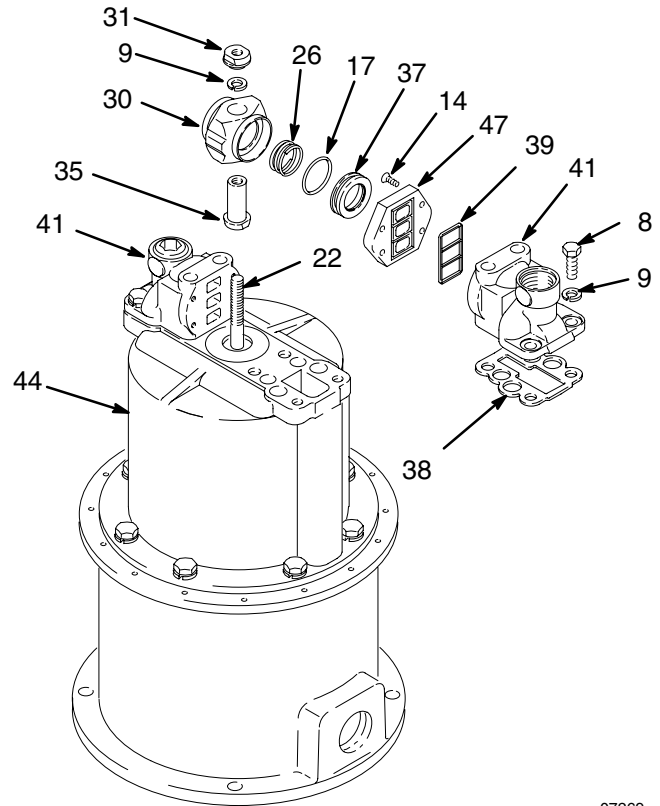

**Fig. 4**

07269

# Service

**NOTE:** Refer to Fig. 5 for steps 10 to 17.

10. Remove the washer (27) and rubber pad (28) from the cylinder (44).
11. Remove the trip rod bearing (1), using a 1 in. deep-well socket wrench. Remove the gasket (16), v-block packing (21), and backup washer (20) from the bearing.

## CAUTION

Be careful not to tilt the cylinder when removing it from the piston to avoid damaging the smooth inner surface of the cylinder.

12. Remove the screws (11) and lockwashers (6) and carefully pull the cylinder (44) straight up off the piston (2).
13. Pull the piston (2) and trip rod (22) up out of the base (50 or 66). Remove the o-ring (29) from the piston.

**NOTE:** The connecting rod stud (36) is fastened to the piston shaft (2) with anaerobic sealant, and may be difficult to remove.

## CAUTION

Be careful not to damage the polished surface of the piston shaft.

14. Lock the hex of the piston shaft (2) in a vise and unscrew the connecting rod stud (36) from the piston shaft.

## CAUTION

Handle the trip rod assembly (22) carefully. Nicks and scratches cause premature spring failure.

**NOTE:** A damaged trip rod cannot be repaired; use a new one.

15. Remove the trip rod (22) from the piston (2).

**NOTE:** Check that the clearance between the inside shoulders of the trip rod spring guides is exactly 5.5 in. (139.7 mm). If the clearance is different, replace the trip rod; do not attempt to adjust it.

16. Remove the v-block packing (23), backup washer (24), and gasket (19) from the base (50 or 66).

17. Turn the base over. *On Models 208356 and 625794*, remove the wiper seal (25). Inspect the bearing (67) in place. Remove only if damaged.

*On Model 208357 only*, remove the packing retainer (63), spring (60), male gland (58), v-packings (61), female gland (57), bearing (64), and washer (65). Refer to the parts drawing on page 22.

# Service

Model 208356 Shown

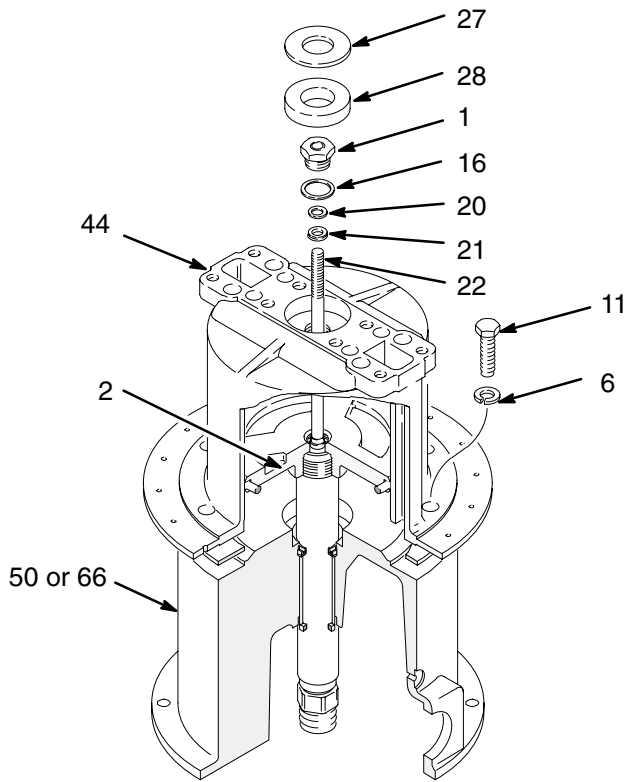

07270

## Detail of Piston

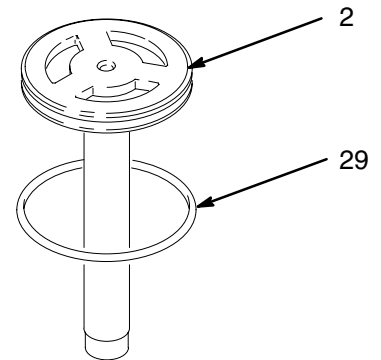

## Detail of Base

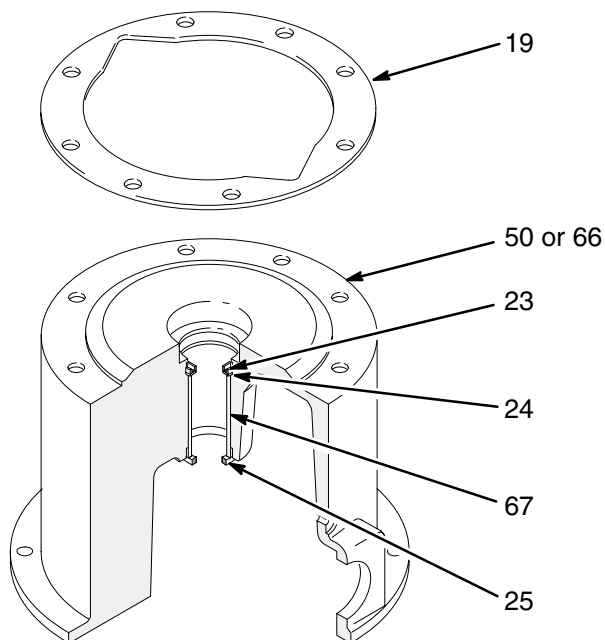

07271

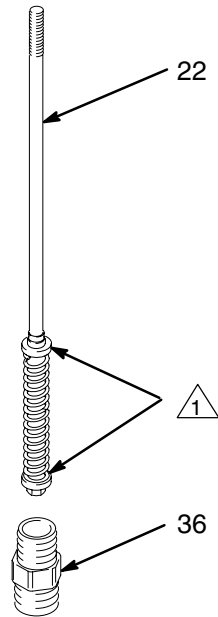

07274

△ 1 Clearance between the inside shoulders must be exactly 5.5 in. (139.7 mm).

Fig. 5



# Service

## Reassembly

1. Clean all parts thoroughly and inspect for wear or damage. Replace parts as necessary.

**NOTE:** Refer to Fig. 6 for steps 2 to 6.

2. Turn the base (50 or 66) upside down.
3. *On Models 208356 and 625794*, if the bearing (67) was removed, press-fit the new bearing so its top edge is flush with the shoulder (S) of the packing cavity. After installation, measure the inner diameter of the bearing. It must be uniformly 1.375 in. (35 mm) to ensure that the piston shaft does not bind. If incorrect, size the bearing while in place; this can be done with a 1.375 in. diameter steel ball.

**NOTE:** *On Model 208357 only*, install the washer (65), bearing (64), female gland (57), v-packings (61) with the lips facing down, male gland (58), spring (60), and packing retainer (63). Refer to the parts drawing on page 22.

4. *On Models 208356 and 625794*, grease the wiper seal (25\*) and press-fit in the base (50).
5. Turn the base upright. Install the backup washer (24\*) in the base (50 or 66). Grease the v-block packing (23\*) and install it in the base so the lips face up.
6. Place the gasket (19\*) on the base (50 or 66) so one of its notches (K) aligns with the optional fluid outlet (L).

### Model 208356 Shown

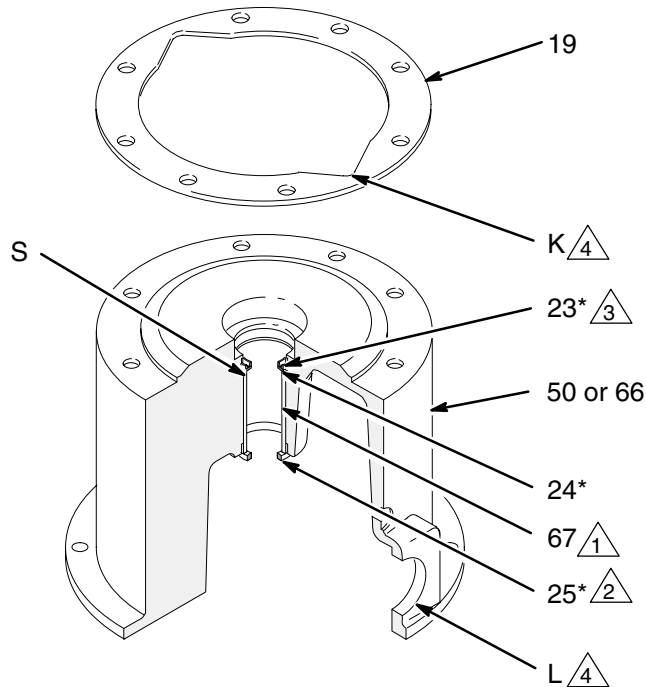

- 1 Inner diameter of the bearing must be uniformly 1.375 in. (35 mm).
- 2 Grease.
- 3 Lips of packing must face up.
- 4 Align notch (K) in gasket (19) with the optional fluid outlet (L) in the base (50 or 66).

Fig. 6

07271

# Service

**NOTE:** Refer to Fig. 7 for steps 7 to 11.

7. Grease the trip rod (22) with light, water-proof grease and slide it into the piston (2) shaft. Clean the threads of the piston and the connecting rod stud (36). Apply Loctite® 242 or the equivalent to both. Screw the stud into the piston and torque to 148–162 ft-lb (200–220 N•m).
8. Place the cylinder (44) upside down on the base (50 or 66). Grease the piston (2), o-ring (29\*), and inside of the cylinder. Place the o-ring around the piston; the o-ring is larger than the piston groove. Install the piston in the cylinder so the excess of the o-ring fits into one of the air channels (M) of the cylinder. Use your fingers to push the o-ring out of the channel and seat it in the piston groove. Very carefully lower the piston into the cylinder.
9. Regrease the inside of the cylinder (44). Carefully turn the piston assembly and cylinder over and guide it into the base (50 or 66). Align one of the cylinder's air channels (M) with the notch (K) in the gasket (19) and with the optional fluid outlet (L) of the base. Install the lockwashers (6) and screws (11) and torque to 9–15 ft-lb (11–20 N•m).
10. Install the backup washer (20\*) and v-block packing (21\*) in the bearing (1) so the lips of the packing face *out of* the bearing. Install the gasket (16\*) on the bearing. Grease the trip rod (22) and thread the bearing onto the trip rod and into the cylinder (44). Use a 1 in. deep-well socket wrench to tighten the bearing to 14–18 ft-lb (19–24 N•m).
11. Install the rubber pad (28) and washer (27) in the cylinder (44).

## CAUTION

When reassembling the sanitary air motor, Model 625794, apply sealant to the cylinder flange to seal out exhaust air that could contaminate the material. Use silicone sealant GE NO. SCS 1300 or equivalent.



# Service

12. See Fig. 8. Make sure the seals (39) are in place on the valve plates (47). Attach the plates to the manifolds with the screws (14).
13. Place the air valve alignment tool (N, order Part No. 168513) on the trip rod (22). Place the gaskets (38\*) on the cylinder (44) so the wide end of the slot aligns with the air channel (M). Install the manifolds (41). The air inlet manifold (the one with the open port, P) must align with the optional fluid outlet in the base (L, Fig. 7). Install the screws (8) and washers (9). Remove the tool.

**NOTE:** The air valve alignment tool (N) ensures proper clearance and alignment for the manifolds.

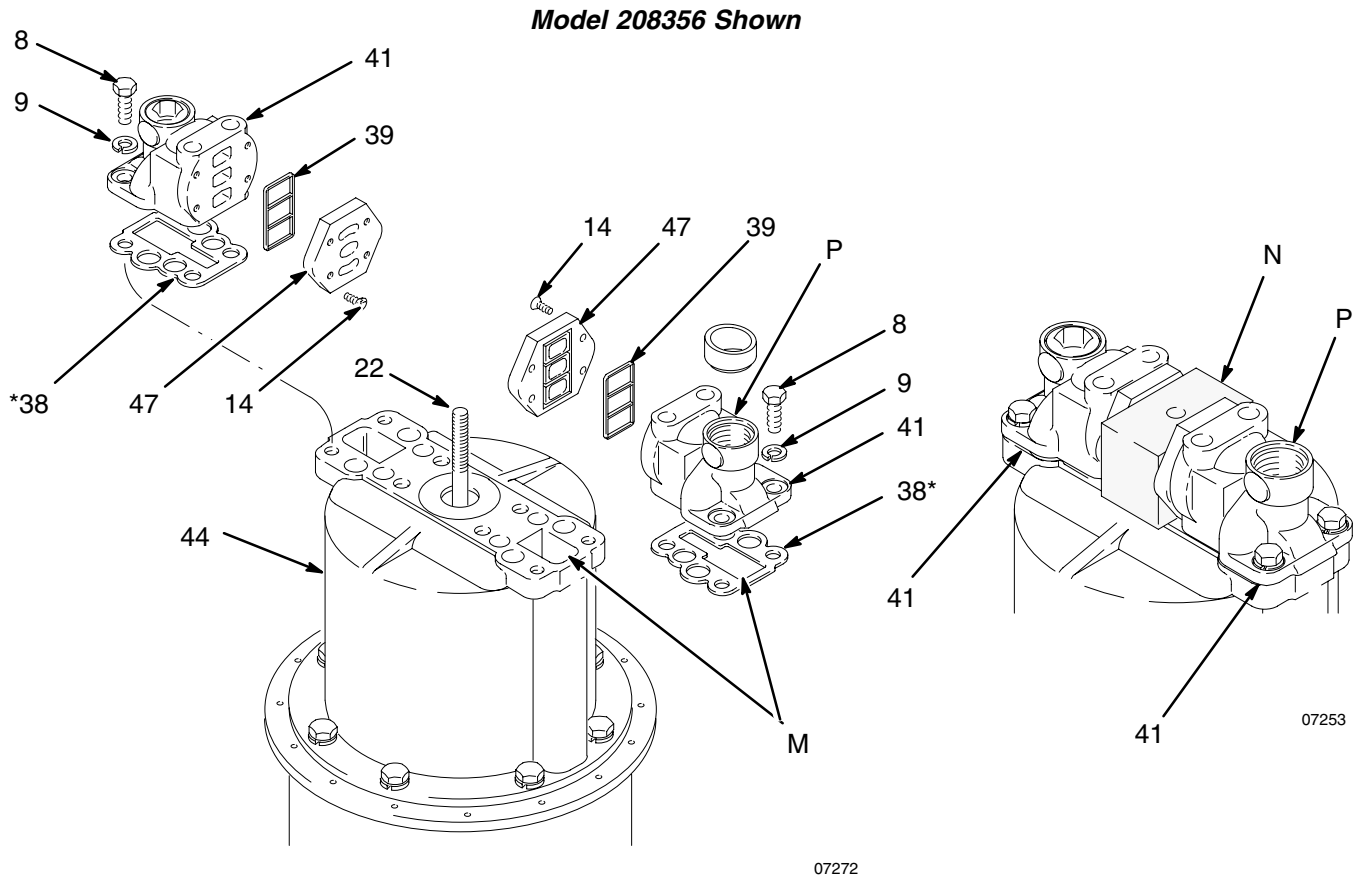

Fig. 8



# Service

**NOTE:** Refer to Fig. 9 for steps 14 to 16.

14. Thread the hub (35) onto the trip rod (22). Lift the rod and grasp it with the padded locking pliers. Screw the hub down as far as possible by hand.
15. Install the air valve housing (30), lockwasher (9), and trip rod nut (31) so the nut is flush with the top of the trip rod (22). Tighten the nut 3/4 turn more, so there is 0.031 in. (0.8 mm) clearance between the top of the rod and the top of the nut. Hold the flats of the trip rod nut (31) with a wrench. With another wrench, tighten the hub (35) to 21–25 ft-lb (28–35 N•m). Turn the valve housing (30) so it rests on the manifolds, then release the pliers.

16. Install an o-ring (17\*) on each director valve (37). Grease the director valves and springs (26) and place them in each side of the air valve housing (30). Hold the parts in the housing and carefully rotate the housing 90° until it slides down between the manifolds (41). **Be very careful not to damage the air director valves (37).**

## Model 208356 Shown

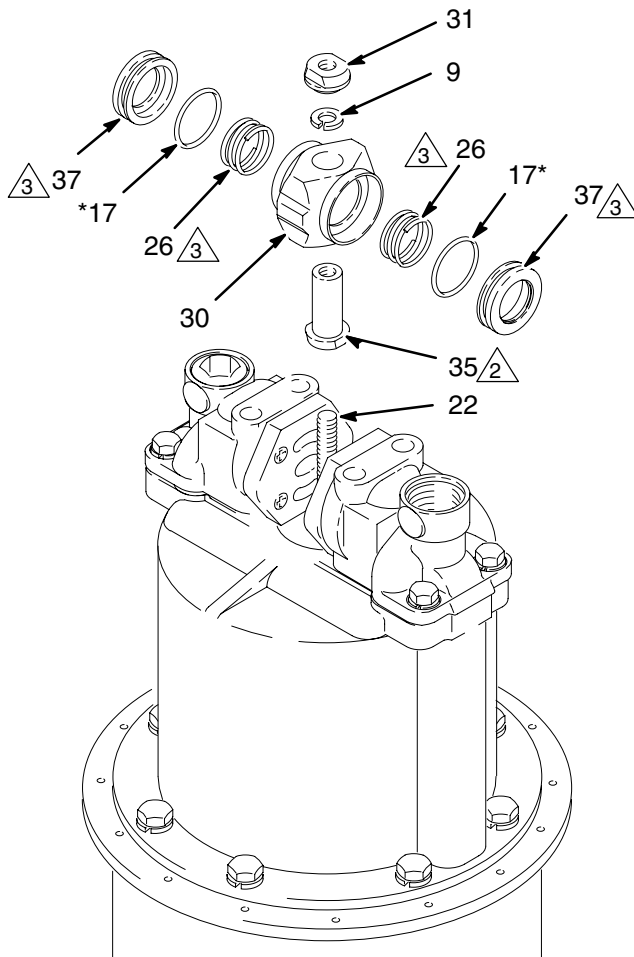

- 1 Make top of nut flush with top of trip rod, then tighten 3/4 turn more. Top of nut (31) must be 0.031" (0.8 mm) from end of rod (22).
- 2 Torque to 21–25 ft-lb (28–35 N•m)
- 3 Grease

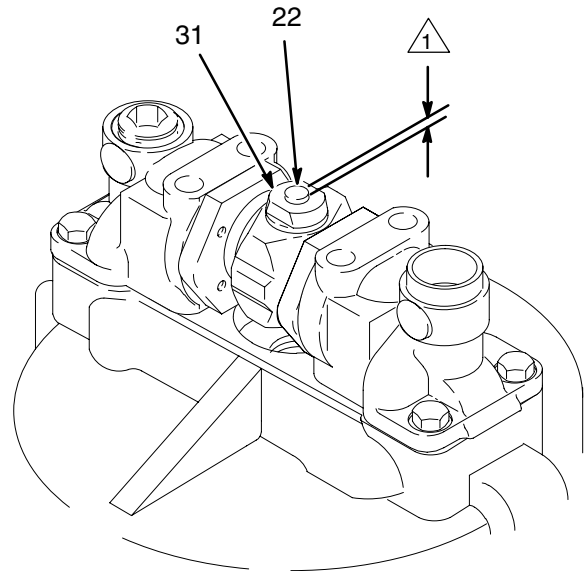

07273

06466

Fig. 9

# Service

**NOTE:** Refer to Fig. 10 for steps 17 to 21.

17. Install the rubber pad (28) and washer (27) in the bottom of the detent housing (45). Grease the plunger (46), assemble the axles (52) and rollers (4) and grease them, and install these parts in the detent housing.
18. Position the detent housing (45) on the manifolds (41), and install the washers (7) and screws (13). Tighten securely.
19. Grease the guides (33) and install with the springs (34) into each side of the detent housing (45). Screw the retainers (32) into both sides of the housing; they should readily screw all the way into the housing by hand. If they do not, the detents are not assembled correctly; inspect, and correct any misalignment. Now firmly tighten the retainers (32).

**⚠ WARNING**

**MOVING PARTS HAZARD**  
Do not operate without the air motor shield in place. Pinching or amputation of fingers or hands may occur. See **MOVING PARTS HAZARD** on page 3.

20. Install the grommet (40), air motor shield (51), and the air inlet fitting (3). Install the screws (10). Reconnect the ground wire.
21. Before connecting the displacement pump, connect an air hose to the motor and run it slowly to check for smooth operation.

**Model 208356 Shown**

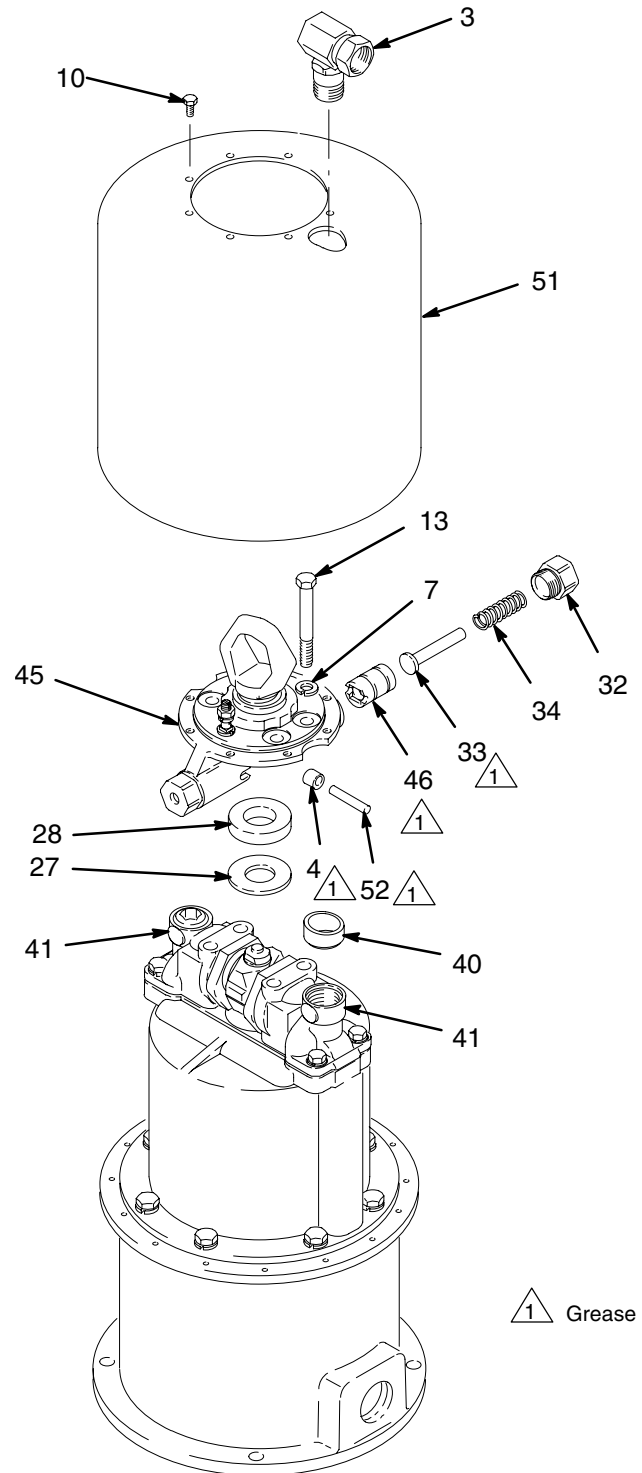

**Fig. 10**

07268



# Parts

Model 902098, Series A  
 Model 208356, Series J  
 Includes items 1-69

▲ 1 Lips of V-Packing Must Face Down

▲ 2 Lips of V-Packing Must Face Up

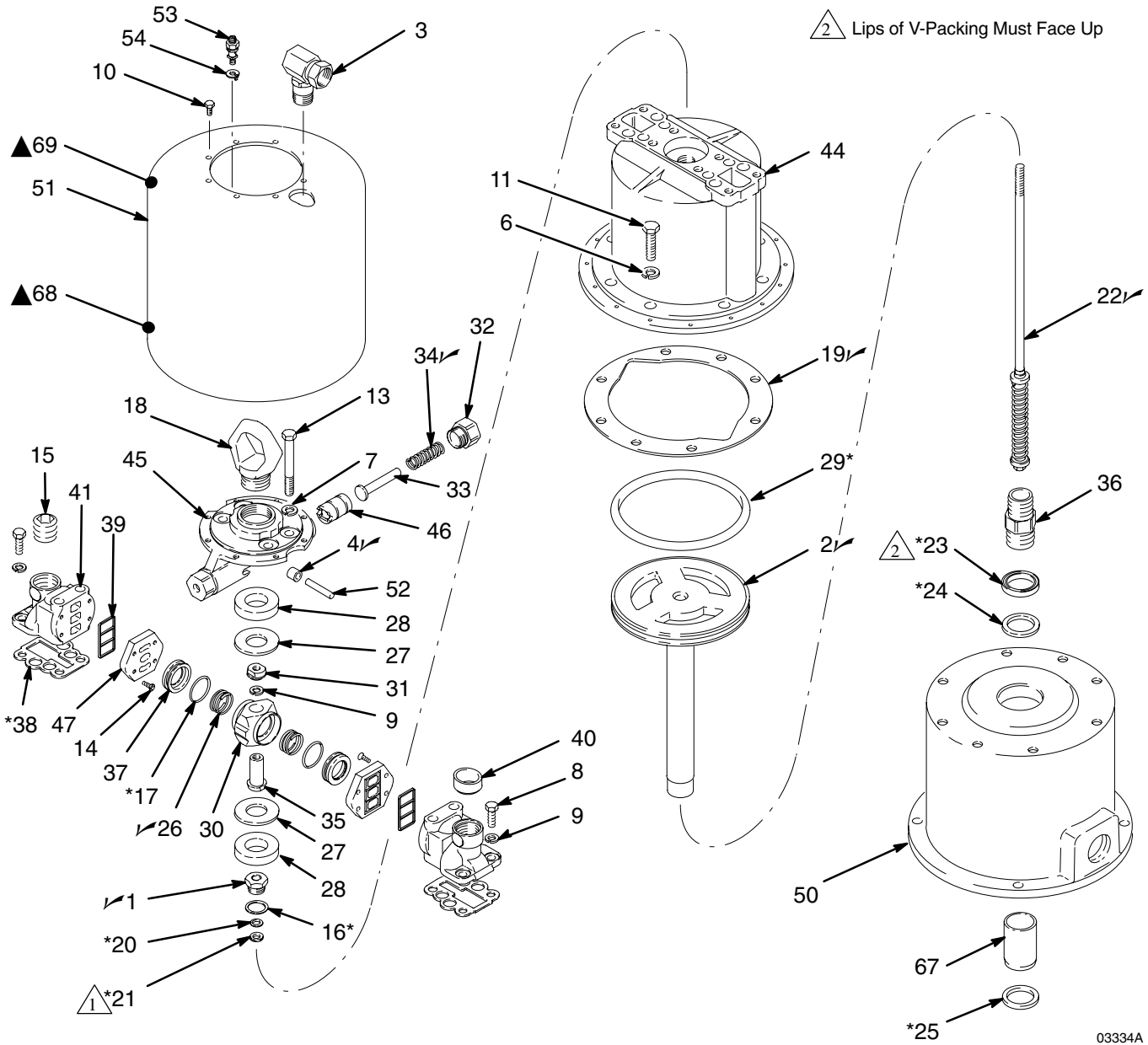

03334A

# Parts

**Model 902098, Series A**  
**Model 208356, Series J**  
**Includes items 1–69**

Ref No.	Part No.	Description	Qty.	Ref No.	Part No.	Description	Qty.
1✓	204649	BEARING	1	33	161588	GUIDE, spring	2
2✓	206710	PISTON ASSY	1	34✓	161589	SPRING, compression	2
3	207648	UNION, 90° adapter; 3/4 npt(m) x 3/4 npsm (f) swivel	1	35	161590	HUB, valve housing	1
4✓	169585	ROLLER, axle	2	36	168180	STUD, connecting rod	1
6	100018	LOCKWASHER, spring; 1/2"	8	37	168182	VALVE, air director	2
7	100052	LOCKWASHER, spring; 7/16"	4	38*	168183	GASKET, air manifold	2
8	100101	SCREW, hex hd cap; 3/8–16 x 1" long	4	39	168184	SEAL, valve plate; buna-N	2
9	100133	LOCKWASHER. spring; 3/8"	5	40	168185	GROMMET	1
10	113161	SCREW, hex hd flange; 1/4–20 x 1/2" long	8	41	168187	MANIFOLD, air	2
11	100424	SCREW, hex hd cap 1/2–13 x 1–1/4" long	8	44	169372	CYLINDER, air motor	1
13	101713	SCREW, hex hd cap; 7/16–14 x 3–1/2" long	4	45	177664	HOUSING, detent	1
14	101716	SCREW, flat hd machine; no. 10–24 x 1/2" long	8	46	169583	PLUNGER, detent	2
15	102726	PLUG, pipe; socket hd; 3/4 npt	1	47	169584	PLATE, valve	2
16*	150647	GASKET	1	50	235995	BASE, air motor (model 208356 only) includes item 67	1
17*	156698	O-RING; buna-N	2		195241	BASE, air motor (model 902098 only)	1
18	180952	RING, lift (model 208356 only)	1	51	169588	SHIELD, air motor	1
	161435	NUT, cap; (model 902098 only)	1	52	169586	AXLE, detent	2
19✓	161556	GASKET	1	53	104029	LUG, grounding	1
20*	161559	WASHER, backup	1	54	104582	WASHER, tab	1
21*	161560	PACKING, v-block; polyurethane	1	67	189059	BEARING	1
22✓	214852	ROD, trip	1	68▲	290331	LABEL, warning; English	1
23*	161562	PACKING, v-block; buna-N	1	69▲	189991	LABEL, warning	1
24*	161563	WASHER, backup	1				
25*	161569	SEAL, felt wiper	1				
26✓	161575	SPRING, compression	2				
27	161576	WASHER, flat	2				
28	161577	PAD, rubber	2				
29*	161578	O-RING; buna-N	1				
30	161585	HOUSING, air valve	1				
31	161586	NUT; 3/8–24	1				
32	161587	RETAINER, detent spring	2				

\* *These parts are included in Repair Kit 206734, which may be purchased separately.*

✓ *Keep these spare parts on hand to reduce down time.*

▲ *Replacement Danger and Warning labels, tags and cards are available at no cost. The 290331 label is also available in the following languages:  
 German (Part No. 290396)  
 French (Part No. 290397)  
 Spanish (Part No. 290398).*

# Parts

Model 208357, Series J  
Includes items 1-69

△1 Lips of V-Packings Must Face Down

△2 Lips of V-Packing Must Face Up

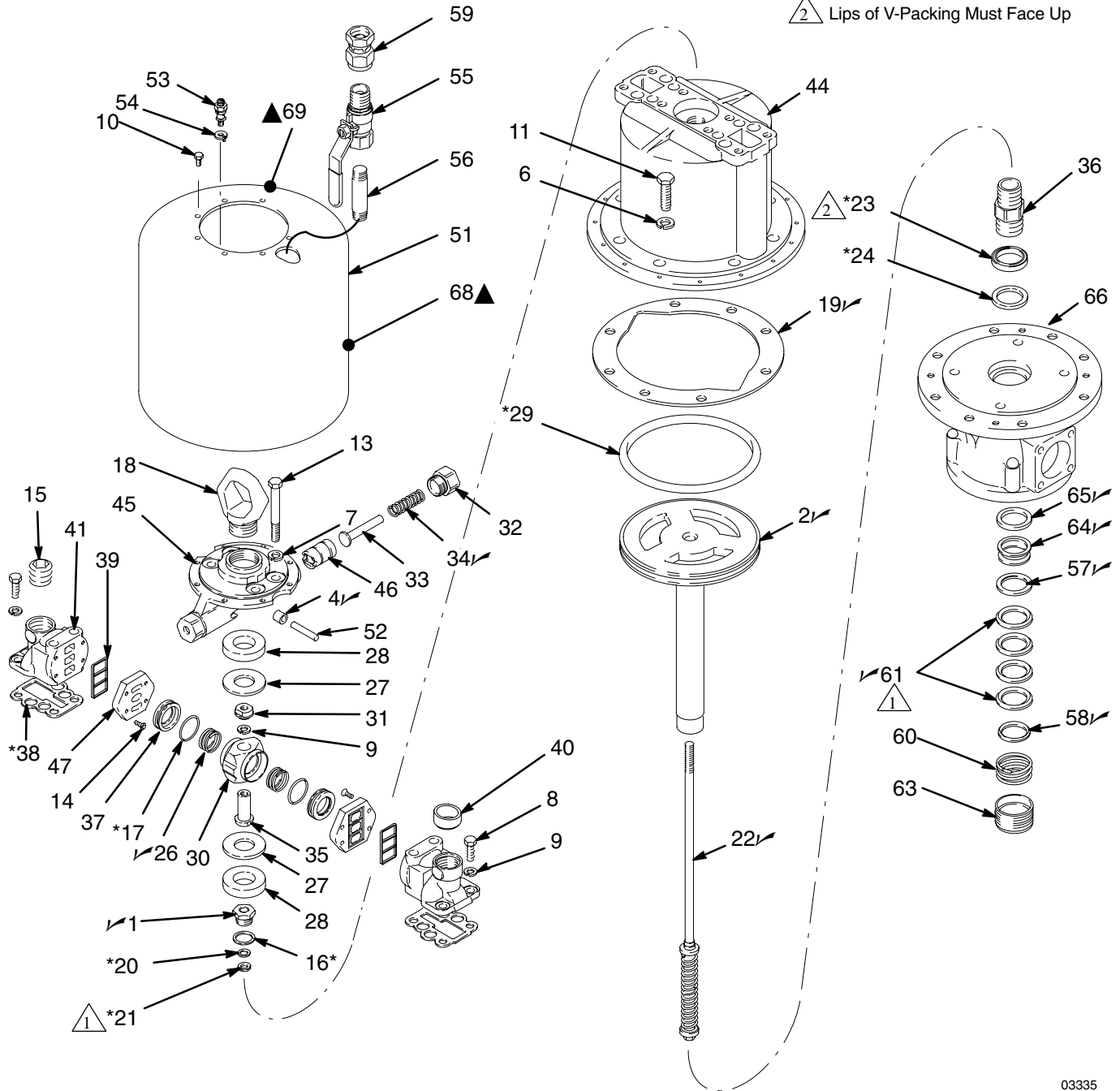

03335

# Parts

## Model 208357, Series J Include items 1–69

Ref No.	Part No.	Description	Qty.	Ref No.	Part No.	Description	Qty.
1✓	204649	BEARING	1	38*	168183	GASKET, air manifold	2
2✓	206710	PISTON ASSY	1	39	168184	SEAL, valve plate; buna-N	2
4✓	169585	ROLLER, axle	2	40	168185	GROMMET	1
6	100018	LOCKWASHER, spring; 1/2"	8	41	168187	MANIFOLD, air	2
7	100052	LOCKWASHER, spring; 7/16"	4	44	169372	CYLINDER, air motor	1
8	100101	SCREW, hex hd cap; 3/8–16 x 1" long	4	45	177664	HOUSING, detent	1
9	100133	LOCKWASHER, spring; 3/8"	5	46	169583	PLUNGER, detent	2
10	113161	SCREW, hex hd flange; 1/4–20 x 1/2" long	8	47	169584	PLATE, valve	2
11	100424	SCREW, hex hd cap 1/2–13 x 1–1/4" long	8	51	169588	SHIELD, air motor	1
13	101713	SCREW, hex hd cap; 7/16–14 x 3–1/2" long	4	52	169586	AXLE, detent	2
14	101716	SCREW, flat hd machine; no. 10–24 x 1/2" long	8	53	104029	LUG, grounding	1
15	102726	PLUG, pipe; socket hd; 3/4 npt	1	54	104582	WASHER, tab	1
16*	150647	GASKET	1	55	107141	VALVE, shutoff; 3/4 npt	1
17*	156698	O-RING, buna-N	2	56	101407	NIPPLE, pipe; 3.4 npt x 3" long	1
18	180952	RING, lift	1	57✓	157636	GLAND, female	1
19✓	161556	GASKET	1	58✓	157638	GLAND, male	1
20*	161559	WASHER, backup	1	59	156172	UNION, straight adapter; 3/4 npt (f) x 3/4 nps(f) swivel	1
21*	161560	PACKING, v-block; polyurethane	1	60	158388	SPRING, compression	1
22✓	214852	ROD, trip	1	61✓	159314	V-PACKING, neoprene	4
23*	161562	PACKING, v-block; buna-N	1	63	162847	RETAINER, packing	1
24*	161563	WASHER, backup	1	64✓	162848	BEARING, throat	1
26✓	161575	SPRING, compression	2	65✓	162849	WASHER, flat	1
27	161576	WASHER, flat	2	66	162935	BASE, air motor	1
28	161577	PAD, rubber	2	68▲	290331	LABEL, warning; English	1
29*	161578	O-RING, buna-N	1	69▲	189991	LABEL, warning	1
30	161585	HOUSING, air valve	1				
31	161586	NUT; 3/8–24	1				
32	161587	RETAINER, detent spring	2				
33	161588	GUIDE, spring	2				
34✓	161589	SPRING, compression	2				
35	161590	HUB, valve housing	1				
36	168180	STUD, connecting rod	1				
37	168182	VALVE, air director	2				

\* These parts are included in Repair Kit 206734, which may be purchased separately.

✓ Keep these spare parts on hand to reduce down time.

▲ Replacement Danger and Warning labels, tags and cards are available at no cost. The 290331 label is also available in the following languages:  
German (Part No. 290396)  
French (Part No. 290397)  
Spanish (Part No. 290398).

# Parts

Model 625794, Series A  
 Include items 1-69

△ 1 Lips of V-Packing Must Face Down

△ 2 Lips of V-Packing Must Face Up

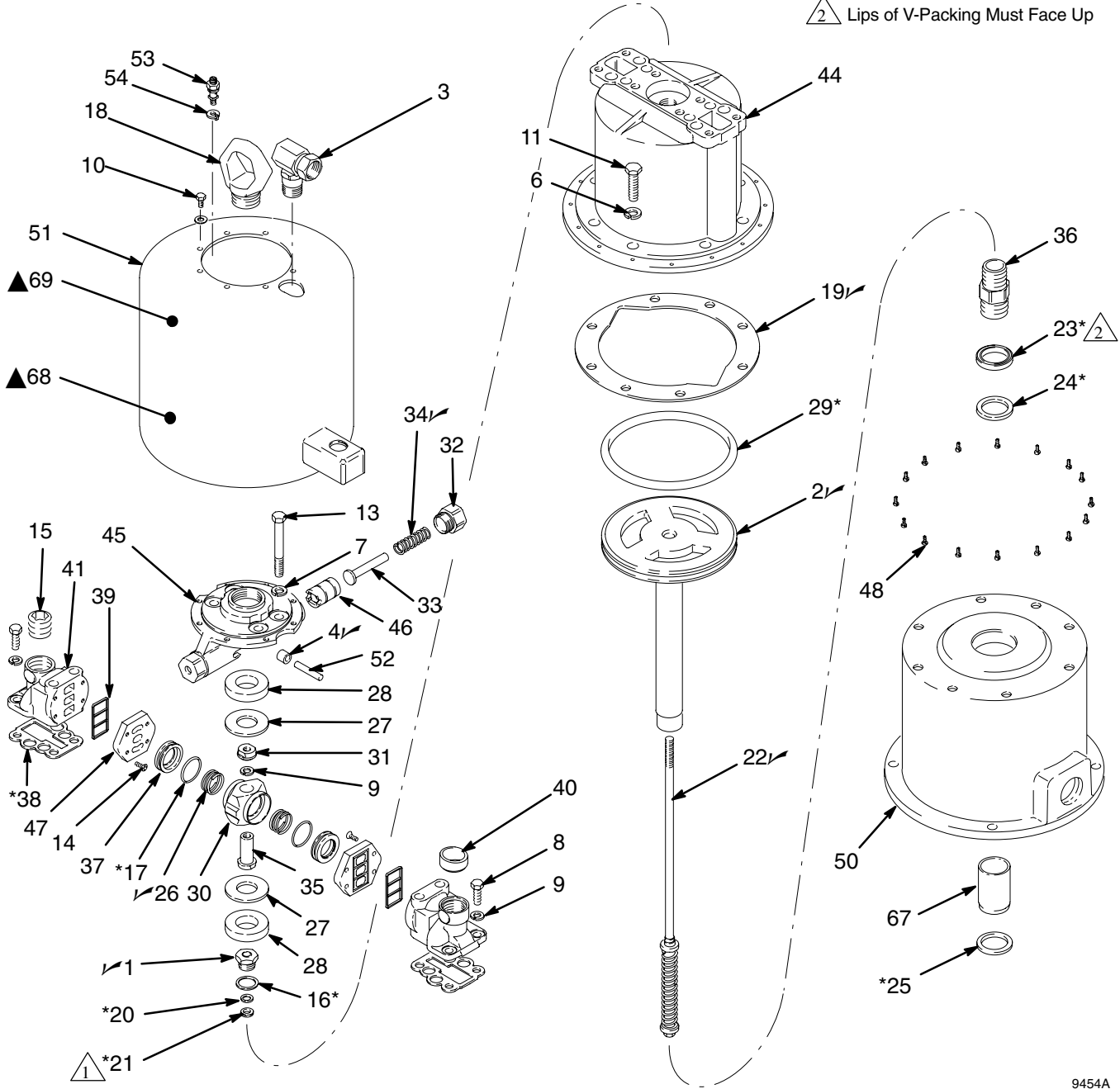

9454A



# Parts

## Model 625794, Series A Include items 1–69

Ref No.	Part No.	Description	Qty.	Ref No.	Part No.	Description	Qty.
1✓	204649	BEARING	1	33	161588	GUIDE, spring	2
2✓	206710	PISTON ASSY	1	34✓	161589	SPRING, compression	2
3	115235	UNION, 90° adapter; 3/4 npt(m) x 3/4 npsm(f) swivel	1	35	161590	HUB, valve housing	1
4✓	169585	ROLLER, axle	2	36	168180	STUD, connecting rod	1
6	100018	LOCKWASHER, spring; 1/2"	8	37	168182	VALVE, air director	2
7	103780	LOCKWASHER, spring; 7/16"	4	38*	168183	GASKET, air manifold	2
8	100101	SCREW, hex hd cap; 3/8–1 x 1" long	4	39	168184	SEAL, valve plate; buna-N	2
9	100133	LOCKWASHER, spring; 3/8"	5	40	168185	GROMMET	1
10	102235	SCREW, hex hd cap; 1/4–20 x 1/2" long	8	41	168187	MANIFOLD, air	2
11	100424	SCREW, hex hd cap; 1/2–13 x 1–1/4" long	8	44	169372	CYLINDER, air motor	1
13	513059	SCREW, hex hd cap; 7/16–14 x 3–1/2" long	4	45	16A544	HOUSING, detent	1
14	101716	SCREW, flat hd machine; no. 10–24 x 1/2" long	8	46	169583	PLUNGER, detent	2
15	102726	PLUG, pipe; socket hd; 3/4 npt	1	47	169584	PLATE, valve	2
16*	150647	GASKET	1	48	100933	SCREW, type "F" self-tapping no. 8–32 x 3/8" long	16
17*	156698	O-RING; buna-N	2	50	189234	BASE, air motor	1
18	180952	RING, lift	1	51	208388	SHIELD, air motor; 1" npt(f) exhaust connection	1
19✓	161556	GASKET	1	52	169586	AXLE, detent	2
20*	161559	WASHER, backup	1	53	104029	LUG, grounding	1
21*	161560	PACKING, v-block; polyurethane	1	54	104582	WASHER, tab	1
22✓	214852	ROD, trip	1	67	189059	BEARING	1
23*	161562	PACKING, v-block; buna-N	1	68▲	290331	LABEL, warning; English	1
24*	161563	WASHER, backup	1	69▲	189991	LABEL, warning	1
25*	161569	SEAL, felt wiper	1				
26✓	161575	SPRING, compression	2				
27	161576	WASHER, flat	2				
28	161577	PAD, rubber	2				
29*	161578	O-RING; buna-N	1				
30	161585	HOUSING, air valve	1				
31	161586	NUT; 3/8–24	1				
32	161587	RETAINER, detent spring	2				

\* These parts are included in Repair Kit 206734, which may be purchased separately.

✓ Keep these spare parts on hand to reduce down time.

▲ Replacement Danger and Warning labels, tags and cards are available at no cost. The 290331 label is also available in the following languages:  
German (Part No. 290396)  
French (Part No. 290397)  
Spanish (Part No. 290398).

# Technical Data

Category	Data
Maximum Incoming Air Pressure	100 psi (0.7 MPa, 7 bar)
Effective Piston Area	38 sq. in. (248 cm <sup>2</sup> )
Piston Diameter	7 in. (178 mm)
Stroke Length	4.75 in. (121 mm)
Air Valves	Dual, slide type
Valve Housing	Balanced, opposing seals and detent rollers
Shipping Weight	Model 208356 and 208357: 74 lb (33.3 kg) Model 625794: 78 lb (35.1 kg)

## Sound Pressure Levels (dBa)

(measured at 1 meter from unit)

Air Motor	Input Air Pressures at 15 cycles per minute			
	0.28 MPa, 2.8 bar (40 psi)	0.48 MPa, 4.8 bar (70 psi)	0.63 MPa, 6.3 bar (90 psi)	0.7 MPa, 7 bar (100 psi)
Bulldog	82.4 dB(A)	87.3 dB(A)	88.5 dB(A)	90.0 dB(A)

## Sound Power Levels (dBa)

(tested in accordance with ISO 9614-2)

Air Motor	Input Air Pressures at 15 cycles per minute			
	0.28 MPa, 2.8 bar (40 psi)	0.48 MPa, 4.8 bar (70 psi)	0.63 MPa, 6.3 bar (90 psi)	0.7 MPa, 7 bar (100 psi)
Bulldog	91.6 dB(A)	95.9 dB(A)	97.4 dB(A)	98.1 dB(A)

# Dimensions

**Models 208356 and 625794**

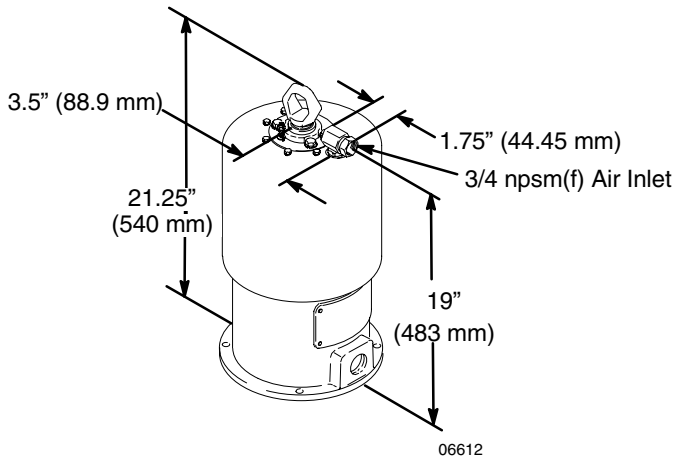

**Model 208357**

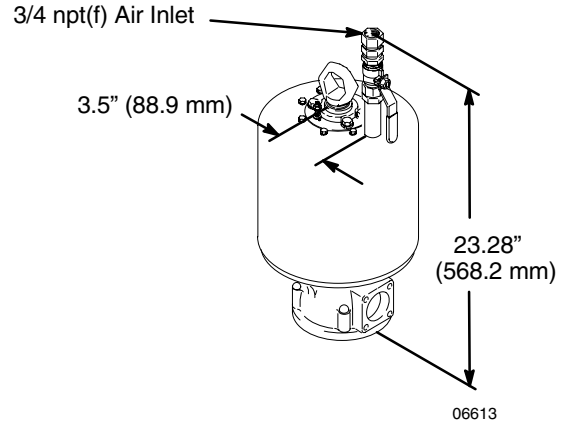

# Mounting Hole Layout

**Models 208356 and 625794**

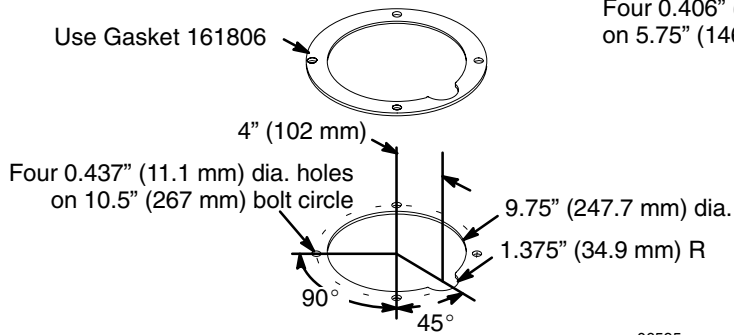

**Model 208357**

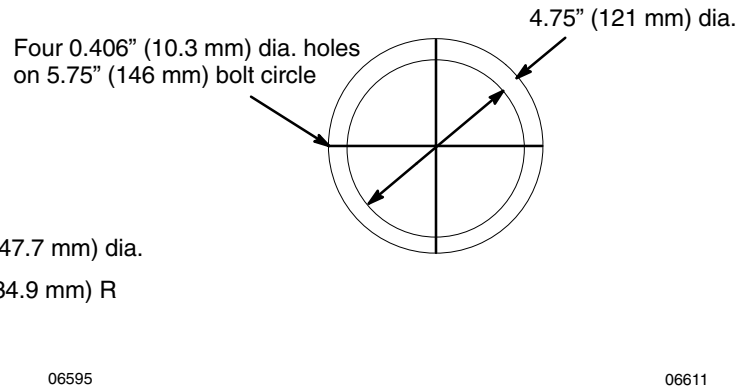

# The Graco Standard Warranty

Graco warrants all equipment manufactured by Graco and bearing its name to be free from defects in material and workmanship on the date of sale by an authorized Graco distributor to the original purchaser for use. With the exception of any special, extended, or limited warranty published by Graco, Graco will, for a period of twelve months from the date of sale, repair or replace any part of the equipment determined by Graco to be defective. This warranty applies only when the equipment is installed, operated and maintained in accordance with Graco's written recommendations.

This warranty does not cover, and Graco shall not be liable for general wear and tear, or any malfunction, damage or wear caused by faulty installation, misapplication, abrasion, corrosion, inadequate or improper maintenance, negligence, accident, tampering, or substitution of non-Graco component parts. Nor shall Graco be liable for malfunction, damage or wear caused by the incompatibility of Graco equipment with structures, accessories, equipment or materials not supplied by Graco, or the improper design, manufacture, installation, operation or maintenance of structures, accessories, equipment or materials not supplied by Graco.

This warranty is conditioned upon the prepaid return of the equipment claimed to be defective to an authorized Graco distributor for verification of the claimed defect. If the claimed defect is verified, Graco will repair or replace free of charge any defective parts. The equipment will be returned to the original purchaser transportation prepaid. If inspection of the equipment does not disclose any defect in material or workmanship, repairs will be made at a reasonable charge, which charges may include the costs of parts, labor, and transportation.

**THIS WARRANTY IS EXCLUSIVE, AND IS IN LIEU OF ANY OTHER WARRANTIES, EXPRESS OR IMPLIED, INCLUDING BUT NOT LIMITED TO WARRANTY OF MERCHANTABILITY OR WARRANTY OF FITNESS FOR A PARTICULAR PURPOSE.**

Graco's sole obligation and buyer's sole remedy for any breach of warranty shall be as set forth above. The buyer agrees that no other remedy (including, but not limited to, incidental or consequential damages for lost profits, lost sales, injury to person or property, or any other incidental or consequential loss) shall be available. Any action for breach of warranty must be brought within two (2) years of the date of sale.

Graco makes no warranty, and disclaims all implied warranties of merchantability and fitness for a particular purpose in connection with accessories, equipment, materials or components sold but not manufactured by Graco. These items sold, but not manufactured by Graco (such as electric motors, switches, hose, etc.), are subject to the warranty, if any, of their manufacturer. Graco will provide purchaser with reasonable assistance in making any claim for breach of these warranties.

In no event will Graco be liable for indirect, incidental, special or consequential damages resulting from Graco supplying equipment hereunder, or the furnishing, performance, or use of any products or other goods sold hereto, whether due to a breach of contract, breach of warranty, the negligence of Graco, or otherwise.

## **FOR GRACO CANADA CUSTOMERS**

The parties acknowledge that they have required that the present document, as well as all documents, notices and legal proceedings entered into, given or instituted pursuant hereto or relating directly or indirectly hereto, be drawn up in English. Les parties reconnaissent avoir convenu que la rédaction du présente document sera en Anglais, ainsi que tous documents, avis et procédures judiciaires exécutés, donnés ou intentés à la suite de ou en rapport, directement ou indirectement, avec les procédures concernées.

## Graco Information

For the latest information about Graco products, visit [www.graco.com](http://www.graco.com).

**TO PLACE AN ORDER**, contact your Graco distributor, or call one of the following numbers to identify the distributor closest to you:

**1-800-328-0211 Toll Free**

**612-623-6921**

**612-378-3505 Fax**

*All written and visual data contained in this document reflects the latest product information available at the time of publication. Graco reserves the right to make changes at any time without notice.*

Original instructions. This manual contains English. MM 307049

**Graco Headquarters:** Minneapolis

**International Offices:** Belgium, China, Japan, Korea

**GRACO INC. P.O. BOX 1441 MINNEAPOLIS, MN 55440-1441**

Copyright 2001, Graco Inc. is registered to ISO 9001

**[www.graco.com](http://www.graco.com)**

Revised 09/2010