

Instructions–Parts List



Monark[®] Air Motor

307043ZAB

EN

For use with Graco fluid handling pumps.

180 psi (1.2 MPa, 12 bar) Maximum Air Working Pressure

Model 206955, Series K

For STANCHION TUBE mounting

Model 205997, Series K

Model 215363, Series D

Model 222791, Series D

For 3 tie rod mounting

Model 207546, Series H

For hinged clamp mounting



Important Safety Instructions

Read all warnings and instructions in this manual.
Save these instructions.

See page 2 for Table of Contents.

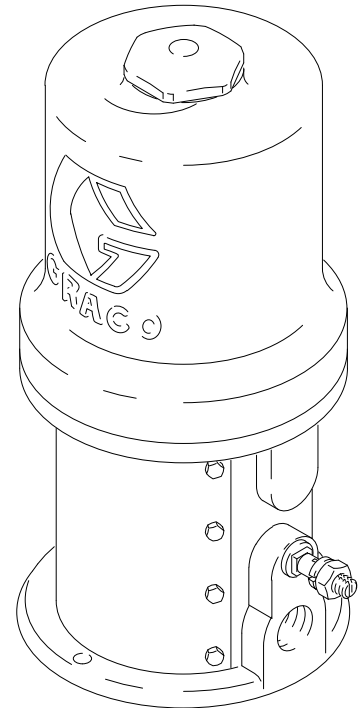

Table of Contents

Warnings	2
Installation	5
Air Motor Service	6
Parts Drawings and Lists	
Model 207546	10
Model 206955	12
Models 205997, 215363, and 222791	14
Accessories	16
Dimensional Drawings	17
Mounting Hole Layouts	17
Technical Data	17
Graco Standard Warranty	18
Graco Information	18

Symbols

Warning Symbol



This symbol alerts you to the possibility of serious injury or death if you do not follow the instructions.

Caution Symbol



This symbol alerts you to the possibility of damage to or destruction of equipment if you do not follow the instructions.

! WARNING



INSTRUCTIONS

EQUIPMENT MISUSE HAZARD

Equipment misuse can cause the equipment to rupture or malfunction and result in serious injury.

- This equipment is for professional use only.
- Read all instruction manuals, tags, and labels before operating the equipment.
- Use the equipment only for its intended purpose. If you are not sure, call your Graco distributor.
- Do not alter or modify this equipment.
- Check equipment daily. Repair or replace worn or damaged parts immediately.
- Do not exceed the maximum working pressure of the lowest rated component in your system. This equipment has a **180 psi (12 bar, 1.2 MPa) maximum incoming air pressure.**
- Use fluids and solvents which are compatible with the equipment wetted parts. Refer to the **Technical Data** section of all equipment manuals. Read the fluid and solvent manufacturer's warnings.
- Do not use hoses to pull equipment.
- Route hoses away from traffic areas, sharp edges, moving parts, and hot surfaces. Do not expose Graco hoses to temperatures above 180°F (82°C) or below -40°F (-40°C).
- Wear hearing protection when operating this equipment.
- Do not lift pressurized equipment.
- Comply with all applicable local, state, and national fire, electrical, and safety regulations.

WARNING

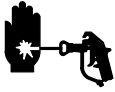

SKIN INJECTION HAZARD

Spray from the gun/dispensing valve, leaks or ruptured components can inject fluid into your body and cause extremely serious injury, including the need for amputation. Fluid splashed in the eyes or on the skin can also cause serious injury.



- Fluid injected into the skin might look like just a cut, but it is a serious injury. **Get immediate surgical treatment.**
- Do not point the gun/valve at anyone or at any part of the body.
- Do not put your hand or fingers over the spray tip/nozzle.
- Do not stop or deflect leaks with your hand, body, glove or rag.
- Do not “blow back” fluid; this is not an air spray system.
- Always have the tip guard and the trigger guard on the gun/valve when spraying.
- Check the gun diffuser operation weekly. Refer to the gun manual.
- Be sure the gun trigger safety operates before spraying.
- Lock the gun trigger safety when you stop spraying.
- Follow the **Pressure Relief Procedure** on page 6 if the spray tip/nozzle clogs and before cleaning, checking or servicing the equipment.
- Tighten all fluid connections before operating the equipment.
- Check the hoses, tubes, and couplings daily. Replace worn or damaged parts immediately. Do not repair high pressure couplings; you must replace the entire hose.
- Use only Graco approved hoses. Do not remove the spring guard that is used to help protect the hose from rupture caused by kinks or bends near the couplings.



MOVING PARTS HAZARD

Moving parts, such as the air motor piston, can pinch or amputate your fingers.

- Keep clear of all moving parts when starting or operating the pump.
- Before servicing the equipment, follow the **Pressure Relief Procedure** on page 6 to prevent the equipment from starting unexpectedly.

WARNING



FIRE AND EXPLOSION HAZARD

Improper grounding, poor ventilation, open flames or sparks can cause a hazardous condition and result in a fire or explosion and serious injury.

- Ground the equipment and the object being sprayed. Refer to **Grounding** on page 5.
- If there is any static sparking or you feel an electric shock while using this equipment, **stop spraying/dispensing immediately**. Do not use the equipment until you identify and correct the problem.
- Provide fresh air ventilation to avoid the buildup of flammable fumes from solvents or the fluid being sprayed/dispensed.
- Keep the spray/dispense area free of debris, including solvent, rags, and gasoline.
- Electrically disconnect all equipment in the spray/dispense area.
- Extinguish all open flames or pilot lights in the spray/dispense area.
- Do not smoke in the spray/dispense area.
- Do not turn on or off any light switch in the spray/dispense area while operating or if fumes are present.
- Do not operate a gasoline engine in the spray/dispense area.



TOXIC FLUID HAZARD

Hazardous fluid or toxic fumes can cause serious injury or death if splashed in the eyes or on the skin, inhaled, or swallowed.

- Know the specific hazards of the fluid you are using.
- Store hazardous fluid in an approved container. Dispose of hazardous fluid according to all local, state and national guidelines.
- Always wear protective eyewear, gloves, clothing and respirator as recommended by the fluid and solvent manufacturer.

Installation

Grounding

⚠ WARNING



FIRE AND EXPLOSION HAZARD
Before operating the pump, ground the system as explained below. Also read the section **FIRE AND EXPLOSION HAZARD** on page 4.

Proper grounding is an essential part of maintaining a safe system.

To reduce the risk of static sparking, ground the pump. Check your local electrical code for detailed grounding instructions for your area and type of equipment. Be sure to ground all of this equipment:

1. *Pump*: use a ground wire and clamp as shown in Fig. 1.
2. *Air and fluid hoses*: use only electrically conductive hoses.
3. *Air compressor*: follow manufacturer's recommendations.
4. *Fluid supply container*: according to local code.
5. *To maintain grounding continuity when flushing or relieving pressure*, always hold a metal part of the gun/valve firmly to the side of a grounded metal pail, then trigger the gun/valve.

To ground the pump:

To ground the pump, loosen the grounding lug locknut (W) and washer (X). Insert one end of a 12 ga (1.5 mm²) minimum ground wire (Y) into the slot in lug (Z) and tighten the locknut securely. Connect the other end of the wire to a true earth ground. Order 222011, Ground Wire and Clamp.

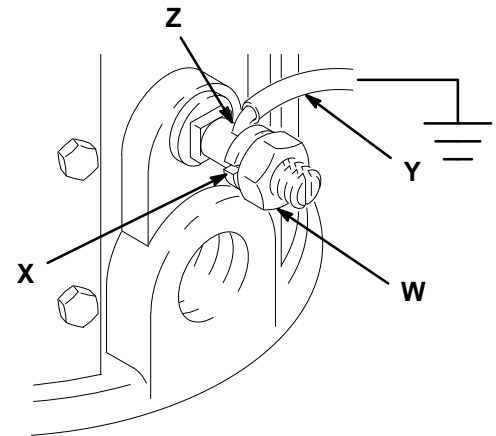

Fig. 1

04111

Air Motor Service

Pressure Relief Procedure

WARNING



SKIN INJECTION HAZARD

The system pressure must be manually relieved to prevent the system from starting or spraying/dispensing accidentally. Fluid under high pressure can be injected through the skin and cause serious injury. To reduce the risk of an injury from injection, splashing fluid, or moving parts, follow the **Pressure Relief Procedure** whenever you:

- are instructed to relieve the pressure,
- stop spraying/dispensing,
- check or service any of the system equipment,
- or install or clean the spray tip/nozzle.

1. Close the pump air regulator and the bleed-type master air valve (required in your system).
2. Hold a metal part of the spray gun/dispensing valve firmly to a grounded metal waste container and trigger the gun/valve to relieve the fluid pressure.

Before You Start

- Be sure you have all necessary parts on hand. **Air Motor Repair Kit 206728** includes repair parts for the motor. Use all the parts in the kit for the best results. Parts included in the kit are marked with an asterisk, for example (19*), in the text and drawings. See **Parts List** on pages 10 – 14.
- For best results keep parts marked with one asterisk on hand to reduce down time.
- Two accessory tools should be used: **Padded Pliers, 207579**, are used to grip the trip rod without damaging its surface, and a **0.145-in. (3.7 mm) Gauge, 171818**, is used to assure the proper clearance between the poppets and the piston.

Disassembly

1. Flush the pump.

WARNING

To reduce the risk of serious injury whenever you are instructed to relieve pressure, always follow the **Pressure Relief Procedure** above.

2. **Relieve the pressure.**
3. Remove the pump according to the instructions in the pump manual.
4. Place the air motor base (F) in a vise with the air motor up.
5. Loosen the cap nut (B). Pull up the cap nut, grip the trip rod (C) with the padded pliers, and screw the cap nut off of the rod.

CAUTION

Do not damage the plated surface of the trip rod (C). Damaging the surface of the trip rod can result in erratic air motor operation. Use the special padded pliers 207579 to grasp the rod.

6. Remove the six screws (D) holding the cylinder (E) to the base (F). Carefully pull the cylinder straight up off of the piston assembly (G).

CAUTION

To avoid damaging the cylinder wall, lift the cylinder straight up off of the piston. Never tilt the cylinder as it is being removed.

Air Motor Service

7. Pull the piston assembly (G) from the air motor base (F), and set it aside.
8. Remove the bearing housing assembly (26 or 27) for all Models except Model 206955. Remove and wipe the seat clean with a cloth. For model 206955, remove retainer ring (3) and bearing (4). Remove seal (2, 27 or 28).
9. Remove the base from the vise, and set it upright on the workbench.
10. Place the piston rod flats in a vise.

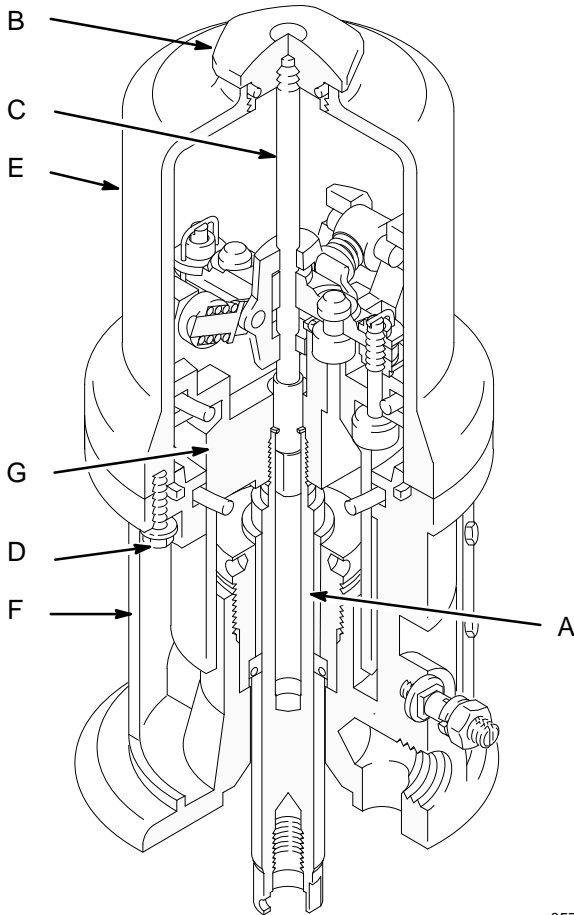

Fig. 2

05703

11. Use a screwdriver to push down on the trip rod yoke (O), and snap the toggles down. See Fig. 3.

WARNING



MOVING PARTS HAZARD

To reduce the risk of pinching or amputating your fingers, keep your fingers clear of the toggle assemblies when you are snapping the toggles (U in Fig. 3) up or down.

12. *In this step, while you are prying with the screwdriver with one hand, cover the toggle assemblies with your other hand so as to catch the spring-loaded toggle assemblies when they snap out of the lugs.* Place the tip of a screwdriver into the piston between the piston lugs (P) below the pivot pins (Q) on the toggles, pry up with the screwdriver handle to compress the springs on the toggle assembly (U) up and away from the piston lugs, and remove the parts. See Fig. 3.

Air Motor Service

13. Straighten the lockwires (L*) and remove them from the upper valve nuts (J*). Screw the upper valve nuts off. Remove the trip rod yoke (O), actuator (V), and trip rod (C).
14. Unscrew the bottom valve nuts (K*), and remove the poppets (N*). Make sure the valve bar spring clips (W) are not worn or damaged and that they properly guide the actuator (V).
15. Remove the exhaust valve poppets (M) by cutting them with a side cutter, then pull them out of the actuator (V).
16. Remove piston o-ring (Z) and internal base o-ring (15* or 19*). Inspect o-rings.
17. Clean all the parts carefully in a compatible solvent and inspect them for wear or damage. Use all the repair kit parts during reassembly, and replace other parts as necessary.
18. Check the surfaces of the piston, piston rod, and cylinder wall for scratches or wear. A scored rod will cause premature packing wear and leaking.

Reassembly

1. Place the piston rod (A) flats in the vise with the air motor up.
2. Pull the exhaust valve poppets (M*) into the valve actuator (V), and clip off the top parts of the poppets (shown with dotted lines in the **Cutaway View** in Fig. 3).
3. Install the grommets (Y*) in the actuator (V), place the inlet valve poppets (N*) in the piston, and thread the bottom valve nuts (K*) onto the inlet valve poppets until there are a few threads left before the threads run out.

NOTE: If you thread the valve nuts too far down onto the poppets, they will run off of the threaded part of the poppets.

4. Place the actuator (V) in the yoke (O) and insert the trip rod (C) through them. Thread a 5/16–18 unc nut on the trip rod to prevent it from sliding into the piston when assembling. Grease the trip rod/actuator/yoke assembly heavily and place into the piston with the inlet valve poppets (N*) going through the grommets (Y*).
5. Thread the top valve nuts (J*) onto the inlet valve poppets (N*) until one thread of the inlet valve poppets is exposed above the valve nuts.

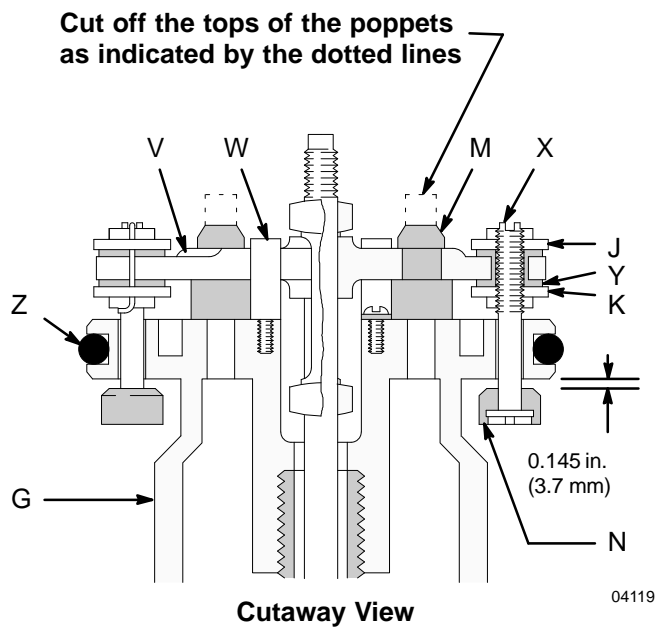
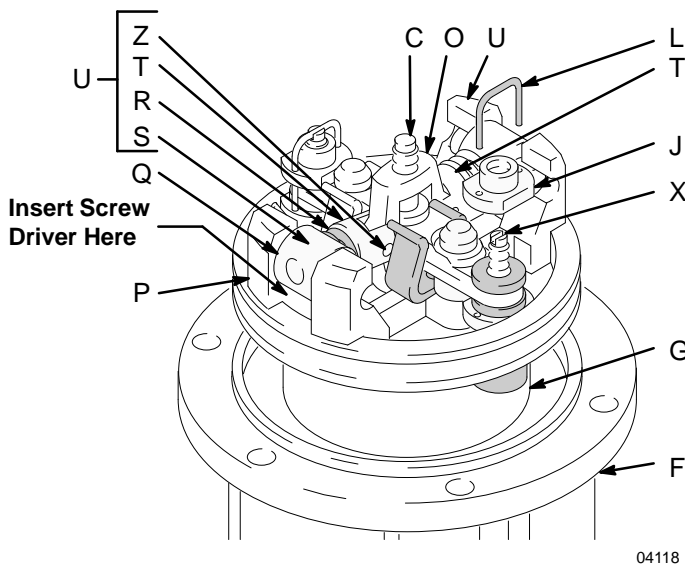

Fig. 3

Air Motor Service

6. Install the toggle pins (Z) in the yoke (O). Assemble the toggle assembly (U) by placing a well greased spring onto the toggle arm (T) and then the toggle rocker (S). Place the toggle arm (T) ends of the toggle assembly (U) onto the toggle pins, and snap the pivot pin (S) ends of the toggle assembly into the lugs (P).
7. Set gap on inlet valve (N) using the .145 in. (3.68 mm) side of gauge 171818. Rotate valve stem (X*) until snug against gauge, then back off until valve stem slot is lined up with wire holes in valve nut (J*) (do not back off more than 1/2 turn). See the **Cutaway View Fig. 3**.
8. Tighten the bottom valve nuts (K*) securely by hand.
9. Align the holes in the valve nuts (K*) and the slots on the tops of the inlet valve poppets (N*), and drop the lock wires (L*) through the holes in the valve nuts and into the slots in the inlet valve poppets. Pull the lock wires down tightly, and bend the ends about 120° with needle-pliers so that they cannot be pulled back out of the holes.

CAUTION

Never re-use the old lock wires. They will get brittle and break easily from too much bending.
Do not score the lock wires when you bend them because they will break on the scoring.

10. Grease and install the new o-rings on the piston assembly (G) and in the groove in the air motor base (F).
11. Clamp the air motor base (F) in a vise by closing the vise jaws on the flange.
12. Grease and install the seal (2, 27 or 28) into the air motor base (F). Install bearing (4) and ring retainer (3) into the base for Model 206955. Grease and install the bearing housing assembly (26 or 27) for all other models.

13. Grease and install the bearing housing assembly (26 or 27) for all Models except Model 206955, or seal (2*), ring retainer (3) and bearing (4) for Model 206955 into the air motor base (F).
14. Slide the piston rod (A) down through the bearing housing assembly, and lower the piston assembly (G) into the air motor base (F).
15. Carefully lower the cylinder (E) straight down onto the piston assembly (G). Tighten the six screws (D) holding the cylinder to the base (F).

CAUTION

To avoid damaging the cylinder wall, lower the cylinder straight down onto the piston. Never tilt the cylinder as it is being lowered.

16. Grip the trip rod (C) with padded pliers. Remove the 5/16 nut from the top of the trip rod. Screw the cap nut (B) onto the trip rod (C), push the cap nut down, and screw it into the top of the cylinder (E).

WARNING



MOVING PARTS HAZARD

Never operate the air motor with the air motor identification plates removed. The piston and associated parts can amputate a hand or finger caught between them.

17. Replace the identification plates (19, 23 or 26) before operating the air motor.
18. Before remounting the the air motor to the pump, connect an air hose and run the air motor slowly, starting with just enough air pressure to make the air motor run, and make sure that it operates smoothly.
19. Reconnect the ground wire before regular operation.

Parts

HINGED CLAMP MOUNTING: SANITARY
Model 207546, Series H, Air Motor Assembly
 Includes items 1–36

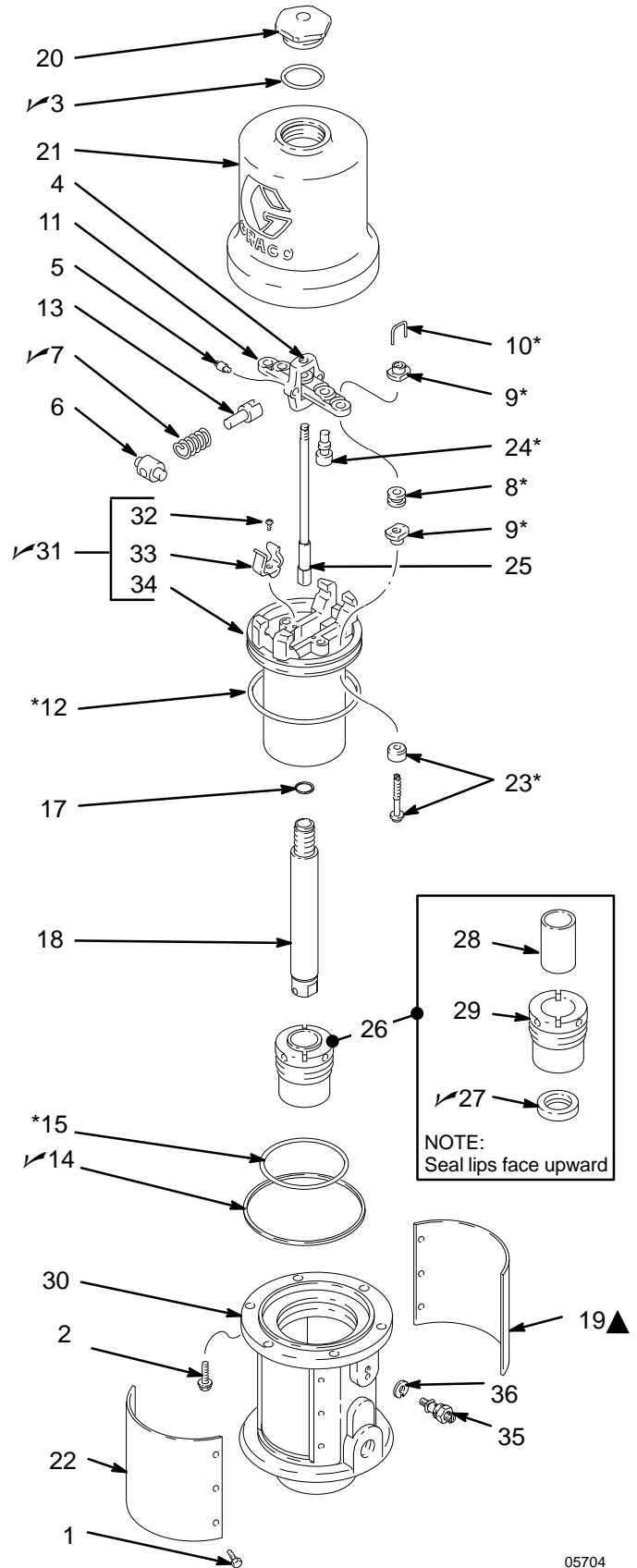

05704

Parts

HINGED CLAMP MOUNTING: SANITARY Model 207546, Series H, Air Motor Assembly Includes items 1–36

Ref. No.	Part No.	Description	Qty.	Ref. No.	Part No.	Description	Qty.
1	17M262	SCREW , thread-forming, hex head; #8–32 x 0.375 in. (9.5 mm)	8	28	101526	• BEARING	1
2	101578	SCREW, hex head; 5/16 x 0.875 in. (10 mm) long	6	29		• HOUSING, bearing (not sold separately)	1
3✓	156698	O-RING; buna-N	1	30	239113	BASE	1
4	158360	YOKE, rod, trip	1	31✓	214036	PISTON Assy; Includes items 32–34 (also includes repair kit 206728 when ordered as a replacement part)	1
5	158362	PIN, toggle	2	32	102975	• SCREW, rd hd mach; no. 6–32 x 0.25" (6.3 mm)	2
6	158364	ROCKER, toggle	2	33	172866	• CLIP, spring	2
7✓	167585	SPRING, helical compression	2	34		• PISTON, bare (not sold separately)	1
8*	158367	GROMMET, rubber, air intake	2	35	104029	LUG, grounding	1
9*	160261	NUT, adjusting	4	36	104582	WASHER, tab	1
10*	160618	LOCKWIRE, transfer valve	2				
11	172867	ACTUATOR, valve	1				
12*	160621	O-RING, nitrile rubber	1				
13	160623	ARM, toggle	2				
14✓	160624	O-RING, buna-N	1				
15*	160625	O-RING, buna-N	1				
17✓	160932	GASKET; copper	1				
18	177136	ROD; piston	1				
19▲	172573	PLATE, warning (English)	1				
20	169627	NUT, cap	1				
21	169628	CYLINDER	1				
22	172572	PLATE, identification	1				
23*	236079	POPPET, valve; urethane	2				
24*	170709	POPPET, valve; urethane	2				
25	203965	ROD, trip	1				
26	207547	BEARING HOUSING Assy; Includes items 27–29	1				
27✓	16H224	• SEAL	1				
					290460	FRENCH	
					290461	GERMAN	
					290462	SPANISH	

✓ *Keep these spare parts on hand to reduce down time.*

* *These parts are included in Repair Kit 206728, which may be purchased separately. See page 16.*

▲ *If you have operators who do not read English, order one of the following labels from your Graco distributor. Paste the label over the English warning plate (19).*

Parts

STANCHION TUBE MOUNTING
Model 206955, Series K,
Air Motor Assembly
 Includes items 1-37

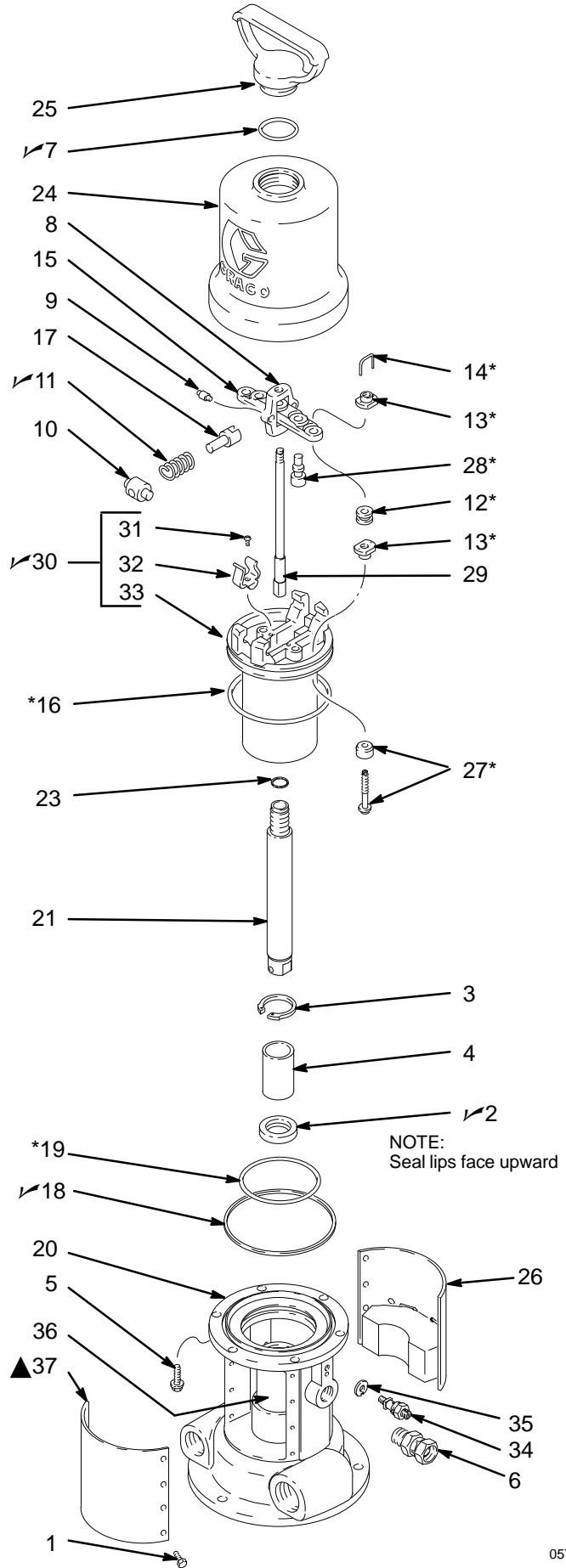

Parts

STANCHION TUBE MOUNTING

Model 206955, Series K, Air Motor Assembly

Includes items 1–37

Ref. No.	Part No.	Description	Qty.	Ref. No.	Part No.	Description	Qty.
1	17M262	SCREW , thread-forming, hex head; #8–32 x 0.375" (9.5 mm).	16	28*	170709	POPPET, valve; urethane	2
2✓	16H224	SEAL	1	29	203965	ROD, trip	1
3	101525	RING, retainer	1	30✓	214036	PISTON Assy; Includes items 31–33 (also includes repair kit 206728 when ordered as a replacement part)	1
4	101526	BEARING	1	31	102975	• SCREW, rd hd mach; no. 6–32 x 0.25" (6.3 mm)	2
5	101578	SCREW, hex head; 5/16 x 0.875 in. (10 mm) long	6	32	172866	• CLIP, spring	2
6	155665	UNION, straight adapter; 3/8 npt(mxf)	1	33		• PISTON, bare (not sold separately)	1
7✓	156698	O-RING; buna-N	1	34	104029	LUG, grounding	1
8	158360	YOKE, rod, trip	1	35	104582	WASHER, tab	1
9	158362	PIN, toggle	2	36	180233	LABEL, warning	1
10	158364	ROCKER, toggle	2	37▲	241650	PLATE, warning (English)	1
11✓	167585	SPRING, helical compression	2	✓ <i>Keep these spare parts on hand to reduce down time.</i>			
12*	158367	GROMMET, rubber, air intake	2	* <i>These parts are included in Repair Kit 206728, which may be purchased separately. See page 16.</i>			
13*	160261	NUT, adjusting	4	▲ <i>If you have operators who do not read English, order one of the following labels from your Graco distributor. Paste the label over the English warning plate (37).</i>			
14*	160618	LOCKWIRE, transfer valve	2	290460	FRENCH		
15	172867	ACTUATOR, valve	1	290461	GERMAN		
16*	160621	O-RING; nitrile rubber	1	290462	SPANISH		
17	160623	ARM, toggle	2				
18✓	160624	O-RING, buna-N	1				
19*	160625	O-RING, buna-N	1				
20	160885	BASE	1				
21	160886	ROD; piston	1				
23✓	160932	GASKET; copper	1				
24	164186	CYLINDER	1				
25	164704	NUT, cap; with carry handle	1				
26	241651	PLATE, identification	1				
27*	236079	POPPET, valve; urethane	2				

Parts

Model 205997, Series K

Air Motor Assembly

Includes: 1, 3-19, 23, 25-34, 36-43

Model 215363, Series D

Air Motor Assembly

Includes: 1, 3-19, 21, 23, 25-34, 37-43

Model 222791, Series D

Air Motor Assembly

Includes: 1-23, 25-34, 39-43

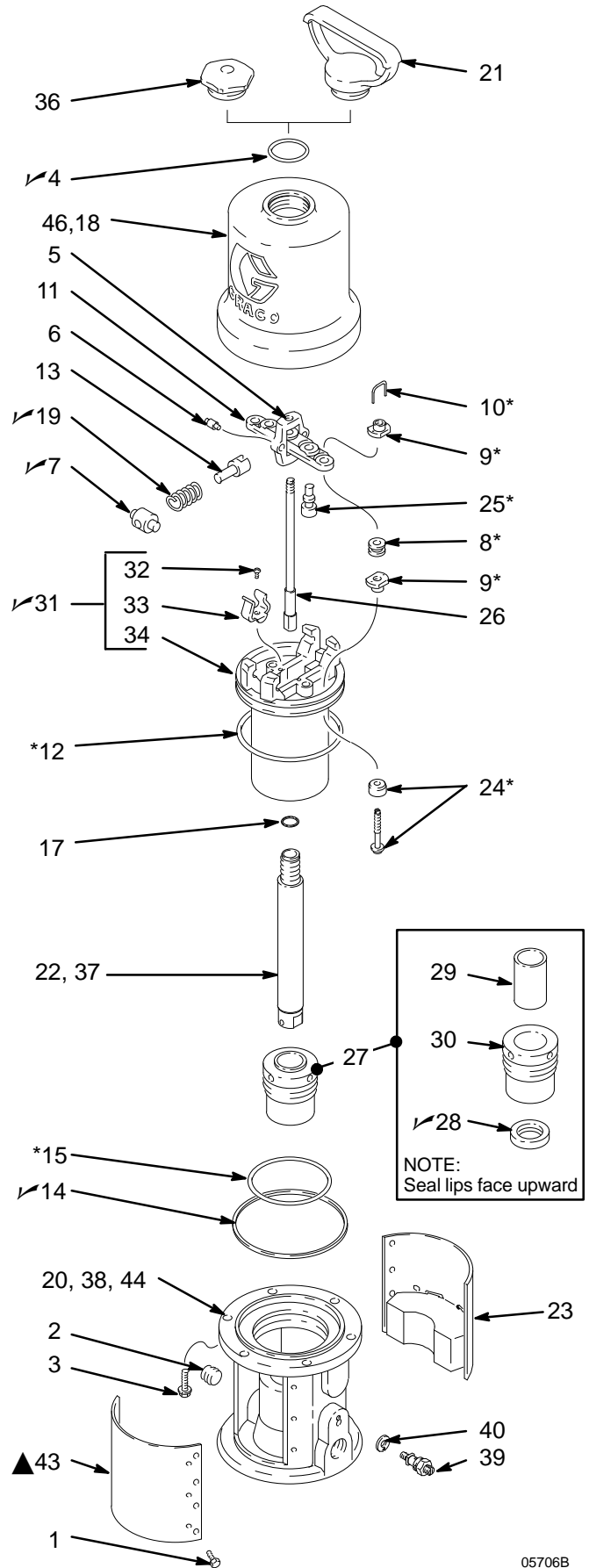

Parts

Model 205997, Series K Air Motor Assembly

Includes: 1, 3–19, 23, 25–34, 36–43

Model 215363, Series D Air Motor Assembly

Includes: 1, 3–19, 21, 23, 25–34, 37–43

Model 222791, Series D Air Motor Assembly

Includes: 1–23, 25–34, 39–43

Ref. No.	Part No.	Description	Qty.	Ref. No.	Part No.	Description	Qty.
1	17M262	SCREW , thread-forming, hex head; #8–32 x 0.375 in. (9.5 mm)	16	31✓	214036	PISTON Assy; Includes items 32–34 (also includes repair kit 206728 when ordered as a replacement part)	1
2	100361	PLUG, pipe; 1/2 in. npt	1				
3	101578	SCREW, hex head; 5/16 x 0.875 in. (10 mm) long	6	32	102975	• SCREW, rd hd mach; no. 6–32 x 0.25" (6.3 mm)	2
4✓	156698	O-RING; buna-N	1	33	172866	• CLIP, spring	2
5	158360	YOKE, rod, trip	1	34		• PISTON, bare (not sold separately)	1
6	158362	PIN, toggle	2	36	161435	NUT, cap	1
7✓	158364	ROCKER, toggle	2	37	177136	ROD, piston	1
8*	158367	GROMMET, rubber, air intake	2	38	205998	BASE	1
9*	160261	NUT, adjusting	4	39	104029	LUG, grounding	1
10*	160618	LOCKWIRE, transfer valve	2	40	104582	WASHER, tab	1
11	172867	ACTUATOR, valve	1	42	180233	LABEL, warning	1
12*	160621	O-RING, nitrile rubber	1	43▲	241650	PLATE, warning (English)	1
13	160623	ARM, toggle	2	44	609354	BASE	1
14✓	160624	O-RING, buna-N	1	46	609353	CYLINDER	1
15*	160625	O-RING, buna-N	1				
17✓	160932	GASKET; copper	1				
18	164186	CYLINDER	1				
19✓	167585	SPRING, helical compression	2				
20	184270	BASE	1				
21	164704	NUT, cap; with carry handle	1				
22	164705	ROD; piston	1				
23	241651	PLATE, identification	1				
24*	236079	POPPET, valve; urethane	2				
25*	170709	POPPET, valve; urethane	2				
26	203965	ROD, trip	1				
27	205529	BEARING HOUSING; Includes 28–30	1				
28✓	16H224	• SEAL	1		290460	FRENCH	
29	101526	• BEARING	1		290461	GERMAN	
30	164701	• NUT, packing	1		290462	SPANISH	

✓ *Keep these spare parts on hand to reduce down time.*

* *These parts are included in Repair Kit 206728, which may be purchased separately. See page 16.*

▲ *If you have operators who do not read English, order one of the following labels from your Graco distributor. Paste the label over the English warning plate (43).*

Accessories

BLEED-TYPE MASTER AIR VALVE (REQUIRED)

300 psi (21 bar, 2.1 MPa) Maximum Working Pressure
Relieves air trapped in the air line between the pump
air inlet and this valve when closed.

107141 3/4 npt (m x f) inlet and outlet

107142 1/2 npt (m x f) inlet and outlet

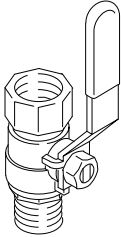

SILENCER KIT 215354

Fits Monark Air Motors Models 206955, 222991,
205997 and 215363. See Instruction Manual 307361.

GROUNDING WIRE 222011

25 ft (7.6 m) long, 12 awg
For grounding pump

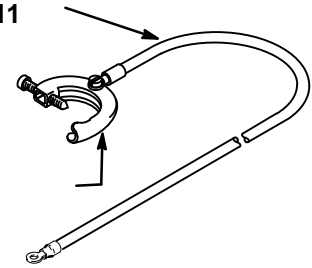

GAUGE 171818

For adjusting the air transfer valves.

TRIP ROD PLIERS 207579

Special padded pliers for gripping the air motor trip rod.

AIR MOTOR REPAIR KIT 206728

Contains replacements parts noted in the **Parts**.

MONARK MUFFLER CONVERSION KIT 241953

Converts Monark motors to new style muffler plates.

Dimensional Drawings

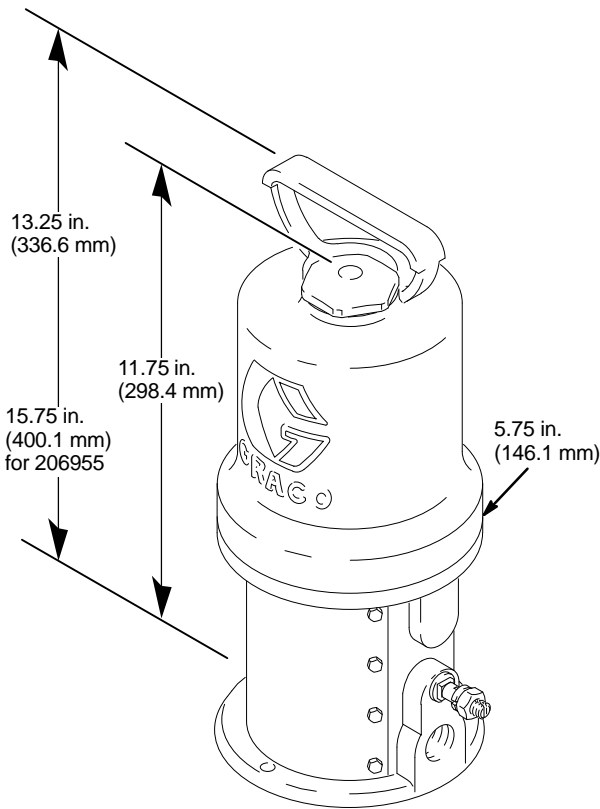

05709

Mounting Hole Layouts

3 Tie Rod Pumps

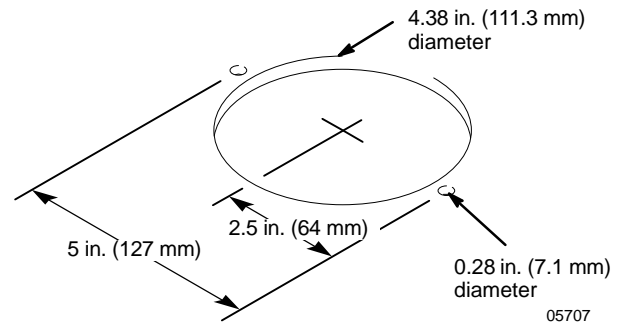

2 Stanchion Tube Pumps

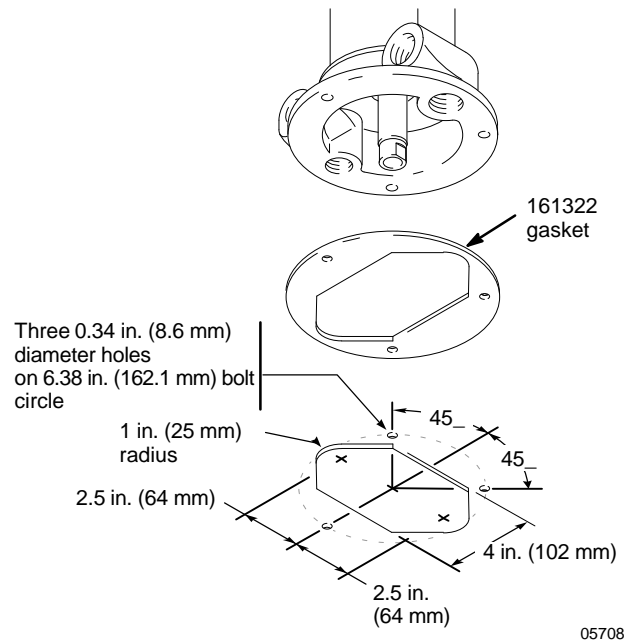

Technical Data

Maximum Working Pressure 180 psi (12 bar, 1.2 MPa)
Effective piston area 7 in.² (45 cm²)
Effective piston diameter 3 in. (76 mm)
Stroke 3 in. (76 mm)
Sound Data*
Sound Level at 180 psi, 25 cycles/min: 96 dBa
Sound Power at 180 psi, 25 cycles/min: 112 dBa

Air Valves Urethane
Valve mechanism Balanced; detented
Seal Nitrile rubber
Approximate weight 13 lb (5.9 Kg)

* Tested in accordance with ISO 3744.

Graco Standard Warranty

Graco warrants all equipment referenced in this document which is manufactured by Graco and bearing its name to be free from defects in material and workmanship on the date of sale to the original purchaser for use. With the exception of any special, extended, or limited warranty published by Graco, Graco will, for a period of twelve months from the date of sale, repair or replace any part of the equipment determined by Graco to be defective. This warranty applies only when the equipment is installed, operated and maintained in accordance with Graco's written recommendations.

This warranty does not cover, and Graco shall not be liable for general wear and tear, or any malfunction, damage or wear caused by faulty installation, misapplication, abrasion, corrosion, inadequate or improper maintenance, negligence, accident, tampering, or substitution of non-Graco component parts. Nor shall Graco be liable for malfunction, damage or wear caused by the incompatibility of Graco equipment with structures, accessories, equipment or materials not supplied by Graco, or the improper design, manufacture, installation, operation or maintenance of structures, accessories, equipment or materials not supplied by Graco.

This warranty is conditioned upon the prepaid return of the equipment claimed to be defective to an authorized Graco distributor for verification of the claimed defect. If the claimed defect is verified, Graco will repair or replace free of charge any defective parts. The equipment will be returned to the original purchaser transportation prepaid. If inspection of the equipment does not disclose any defect in material or workmanship, repairs will be made at a reasonable charge, which charges may include the costs of parts, labor, and transportation.

THIS WARRANTY IS EXCLUSIVE, AND IS IN LIEU OF ANY OTHER WARRANTIES, EXPRESS OR IMPLIED, INCLUDING BUT NOT LIMITED TO WARRANTY OF MERCHANTABILITY OR WARRANTY OF FITNESS FOR A PARTICULAR PURPOSE.

Graco's sole obligation and buyer's sole remedy for any breach of warranty shall be as set forth above. The buyer agrees that no other remedy (including, but not limited to, incidental or consequential damages for lost profits, lost sales, injury to person or property, or any other incidental or consequential loss) shall be available. Any action for breach of warranty must be brought within two (2) years of the date of sale.

Graco makes no warranty, and disclaims all implied warranties of merchantability and fitness for a particular purpose in connection with accessories, equipment, materials or components sold but not manufactured by Graco. These items sold, but not manufactured by Graco (such as electric motors, switches, hose, etc.), are subject to the warranty, if any, of their manufacturer. Graco will provide purchaser with reasonable assistance in making any claim for breach of these warranties.

In no event will Graco be liable for indirect, incidental, special or consequential damages resulting from Graco supplying equipment hereunder, or the furnishing, performance, or use of any products or other goods sold hereto, whether due to a breach of contract, breach of warranty, the negligence of Graco, or otherwise.

FOR GRACO CANADA CUSTOMERS

The parties acknowledge that they have required that the present document, as well as all documents, notices and legal proceedings entered into, given or instituted pursuant hereto or relating directly or indirectly hereto, be drawn up in English. Les parties reconnaissent avoir convenu que la rédaction du présente document sera en Anglais, ainsi que tous documents, avis et procédures judiciaires exécutés, donnés ou intentés à la suite de ou en rapport, directement ou indirectement, avec les procédures concernées.

Graco Information

For the latest information about Graco products, visit www.graco.com.

TO PLACE AN ORDER, contact your Graco distributor, or call one of the following numbers to identify the distributor closest to you:

1-800-328-0211 Toll Free 612-623-6921 612-378-3505 Fax

All written and visual data contained in this document reflects the latest product information available at the time of publication. Graco reserves the right to make changes at any time without notice.

Original instructions. This manual contains English. MM 307043

Graco Headquarters: Minneapolis
International Offices: Belgium, China, Japan, Korea

GRACO INC. AND SUBSIDIARIES • P.O. BOX 1441 • MINNEAPOLIS MN 55440-1441 • USA
Copyright 1970, Graco Inc. All Graco manufacturing locations are registered to ISO 9001.

www.graco.com

Revision ZAB, April 2016